

# Metallkissen · Metal Cushions

Coussins métalliques · Cuscinetti completamente in metallo

Cojines enteramente Metálicos



## D

- **Material:** rostfreier Stahl
- Stoßdämpfend und schwingungsisolierend
- Korrosionsbeständig gegen Lösungsmittel, Säuren, Öle, Fette, Flüssigkeiten und Staub
- Alterungsbeständig - keine bleibenden Verformungen, kein Verhärten und kein Kriechen
- Temperaturbereich: -90°C bis +400°C (optional: +900°C)

## GB

- **Material:** stainless steel
- Shock-absorbing and vibration-isolation
- Corrosion-resistant against solvents, acids, oils, greases, liquids and dust
- Resistant to age - no permanent deformation, no hardening and no creeping
- Temperature: -90°C to +400°C (option: +900°C)

## F

- **Matériau:** Acier inoxydable
- Amortissement des chocs et isolation vibratoire
- Résistant à la corrosion due aux solvants, acides, huiles, graisses, liquides et poussières
- Non-vieillissant - aucune déformation durable, aucun durcissement et aucun fluage
- Température : -90°C jusqu'à +400°C (option: +900°C)

## I

- **Materiale:** acciaio inossidabile
- Ammortizza gli urti e isola dalle oscillazioni
- Resiste alla corrosione da solventi, acidi, oli, grassi, liquidi e polvere
- Resiste all'usura - non si deforma permanentemente, non si indurisce e non striscia
- Temperatura: da -90°C a +400°C (opzione: +900°C)

## E

- **Material:** acero inoxidable
- Amortiguación a choque y Antivibratorio
- Resistente al efecto corrosivo de disolventes, ácidos, aceites, grasas, líquidos y polvo
- Resistente al envejecimiento: no se deforma, no se endurece y no se escurre
- Temperaturas: de -90°C a +400°C (opcional: +900°C)

Архангельск (8182)63-90-72  
Астана (7172)727-132  
Астрахань (8512)99-46-04  
Барнаул (3852)73-04-60  
Белгород (4722)40-23-64  
Брянск (4832)59-03-52  
Владивосток (423)249-28-31  
Волгоград (844)278-03-48  
Вологда (8172)26-41-59  
Воронеж (473)204-51-73  
Екатеринбург (343)384-55-89  
Иваново (4932)77-34-06

Ижевск (3412)26-03-58  
Иркутск (395)279-98-46  
Казань (843)206-01-48  
Калининград (4012)72-03-81  
Калуга (4842)92-23-67  
Кемерово (3842)65-04-62  
Киров (8332)68-02-04  
Краснодар (861)203-40-90  
Красноярск (391)204-63-61  
Курск (4712)77-13-04  
Липецк (4742)52-20-81  
Киргизия (996)312-96-26-47

Магнитогорск (3519)55-03-13  
Москва (495)268-04-70  
Мурманск (8152)59-64-93  
Набережные Челны (8552)20-53-41  
Нижний Новгород (831)429-08-12  
Новокузнецк (3843)20-46-81  
Новосибирск (383)227-86-73  
Омск (3812)21-46-40  
Орел (4862)44-53-42  
Оренбург (3532)37-68-04  
Пенза (8412)22-31-16  
Россия (495)268-04-70

Пермь (342)205-81-47  
Ростов-на-Дону (863)308-18-15  
Рязань (4912)46-61-64  
Самара (846)206-03-16  
Санкт-Петербург (812)309-46-40  
Саратов (845)249-38-78  
Севастополь (8692)22-31-93  
Симферополь (3652)67-13-56  
Смоленск (4812)29-41-54  
Сочи (862)225-72-31  
Ставрополь (8652)20-65-13  
Казахстан (772)734-952-31

Сургут (3462)77-98-35  
Тверь (4822)63-31-35  
Томск (3822)98-41-53  
Тула (4872)74-02-29  
Тюмень (3452)66-21-18  
Ульяновск (8422)24-23-59  
Уфа (347)229-48-12  
Хабаровск (4212)92-98-04  
Челябинск (351)202-03-61  
Череповец (8202)49-02-64  
Ярославль (4852)69-52-93

**D** Zur Berechnung werden folgende Angaben benötigt:

1.	Anzuhebende Masse m (kg)
2.	Erregerfrequenz f (Hz)
3.	Drehzahl (U)
4.	gewünschter Isoliergrad Ig (%)
5.	Anzahl der Metallkissen (n)
6.	Temperatur

**GB** Basic criteria required for sizing:

1.	Mass to be lifted m (kg)
2.	Exciting frequency f (Hz)
3.	Rate of revolutions (U)
4.	Desired degree of isolation Ig (%)
5.	Number of metal cushions (n)
6.	Temperature

**F** Informations nécessaires pour le dimensionnement:

1.	Masse à lever m (kg)
2.	Fréquence d'excitation f (Hz)
3.	Nombre de tours (U)
4.	Dégré d'isolation désiré Ig (%)
5.	Nombre des coussins métalliques (n)
6.	Température

**I** Dati necessari per il calcolo:

1.	Massa da sollevare m (kg)
2.	Frequenza delle vibrazione f (Hz)
3.	Il numero dei giri (U)
4.	Grado d'isolamento desiderato Ig (%)
5.	Numero di cuscinetto completamente in metallo (n)
6.	Temperatura

**E** Para el dimensionado se requieren datos básicos:

1.	Masa a elevar m (kg)
2.	Frecuencia de excitación f (Hz)
3.	Número de revoluciones (U)
4.	Grado de aislamiento deseado Ig (%)
5.	Número de cojines enteramente metálicos (n)
6.	Temperatura

**SCHWINGUNGSISOLIERUNG - VIBRATION ISOLATION - ISOLATION DE VIBRATION  
ANTI VIBRANTE - AISLAMIENTO ANTIVIBRATORIO**

Auswahl - Selection  
**WG-FB 29,2x29,2x19x6,4**



m = 100	$F_i \geq F$	$F = \frac{\text{kg} \times g}{n}$	0,75 kN > 0,25 kN
n = 4			
ferr. = 90 Hz	$f_o \leq \frac{f_{err}}{1,44}$		15 < 62,5 Hz
Ig = 90 %	$I_t \geq I_g \leq 100\%$	$I_t = 1 - \frac{1}{\left(\frac{f_{err}}{f_o}\right)^2} - 1$	97,1% > 90% < 100%
T = 20 °C	T		-90 °C < 30 °C < +400 °C

# WG-RU

Rundlager - Circular Type - Type Circulaire - Tipo Circolare - Tipo Circular

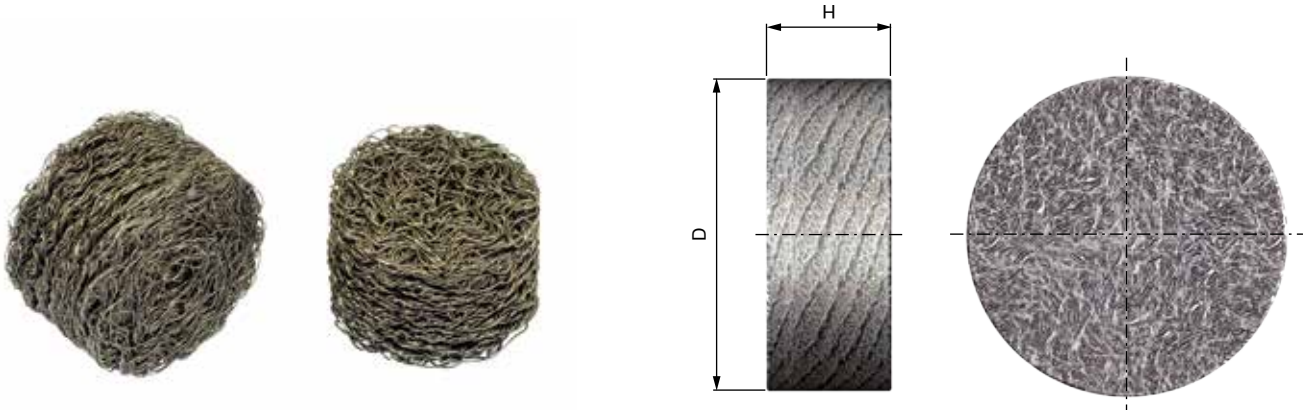

## TECHNISCHE DATEN - SPECIFICATIONS - DONNÉES TECHNIQUES - DATI TECNICI - DATOS TÉCNICOS

	D	H	Tragkraft - Load - Charge Peso - Carga	Eigenfrequenz - Natural frequency - Fréquence propre Frecuencia propia - Frecuencia propia	Einfederung - Static deflection Deformacion - Deflessione statica Deflexion	Gewicht - Weight Poids - Peso Peso
	mm	mm	kN (max.)	Hz	mm	g
WG-RU 23,2x15	23,2	15	1,25	15 - 20	4,5	11
WG-RU 25x15	25,0	15	1,40	15 - 20	4,5	13
WG-RU 35,2x20	35,2	20	2,00	15 - 20	6,2	30
WG-RU 44,2x20	44,2	20	2,50	15 - 20	6,5	50
WG-RU 54,3x20	54,3	20	4,00	15 - 20	6,5	70

# WG-RI

Ringlager - Ring Type - Type Bague - Tipo Anello - Tipo Junta

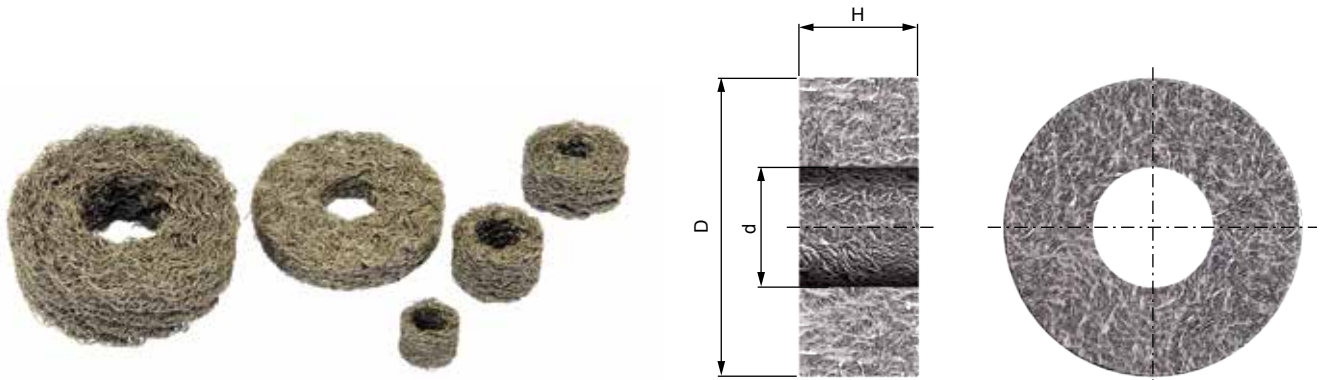

## TECHNISCHE DATEN - SPECIFICATIONS - DONNÉES TECHNIQUES - DATI TECNICI - DATOS TÉCNICOS

	D	H	d	Tragkraft - Load - Charge Peso - Carga	Eigenfrequenz - Natural frequency Fréquence propre - Frecuencia propia Frecuencia propia	Einfederung - Static deflection Deformacion - Deflessione statica Deflexion	Gewicht - Weight Poids - Peso Peso
	mm	mm	mm	kN (max.)	Hz	mm	g
WG-RI 14,8x10x8,7	14,8	10,0	8,7	0,04	15 - 20	2,1	2
WG-RI 19,8x10x7,7	19,8	10,0	7,7	0,35	15 - 20	3,2	5
WG-RI 22x15,5x6,3	22,0	15,5	6,3	0,5	15 - 20	5,5	7
WG-RI 23,6x15,5x11,6	23,6	15,5	11,6	0,6	15 - 20	5,3	8
WG-RI 28,5x15x9,7	28,5	15,0	9,7	0,8	15 - 20	5,3	11
WG-RI 34,5x15x9,7	34,5	15,0	9,7	1,0	15 - 20	5,5	18
WG-RI 40x20x11,8	40,0	20,0	11,8	1,5	15 - 20	6,9	32
WG-RI 42,5x20x21,2	42,5	20,0	21,2	1,5	15 - 20	5,8	32
WG-RI 53,6x20x19,8	53,6	20,0	19,8	2,25	15 - 20	7,0	52
WG-RI 62,6x20x39,2	62,6	20,0	39,2	3,0	15 - 20	5,8	60

## WG-RL

Rundlager mit Befestigungsloch - Circular type for socket head cap screw fixing  
 Type Circulaire avec trou de Fixation - Tipo circolare con foro di fissaggio  
 Tipo circular con agujero para fijación

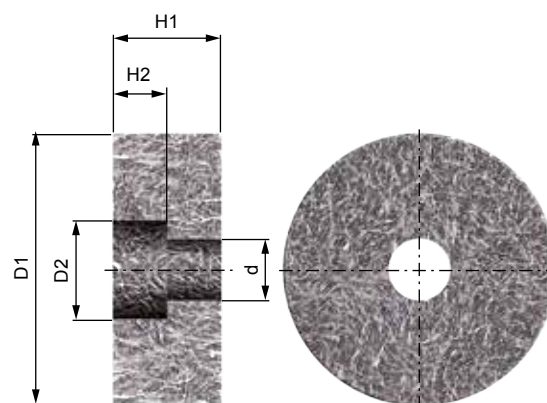

## TECHNISCHE DATEN - SPECIFICATIONS - DONNÉES TECHNIQUES - DATI TECNICI - DATOS TÉCNICOS

	D1	H1	d	D2	H2	Tragkraft - Load - Charge Peso - Carga	Eigenfrequenz - Natural frequency Fréquence propre - Frecuencia propia Frecuencia propia	Einfederung - Static deflection Deformacion - Deflessione statica Deflexion	Gewicht - Weight Poids - Peso Peso
	mm	mm	mm	mm	mm	kN (max.)	Hz	mm	g
WG-RL 20x12,5x5,4	20,0	12,5	5,4	9,5	5,5	0,225	15 - 20	2,8	7
WG-RL 20,2x13x6,3	20,2	13,0	6,3	11,0	6,0	0,3	15 - 20	3,0	7
WG-RL 25x15,5x6,9	25,0	15,5	6,9	12,0	8,5	0,4	15 - 20	3,5	14
WG-RL 35,5x20x9,9	35,5	20,0	9,9	16,0	11,0	0,5	15 - 20	6,0	25
WG-RL 52,5x23x11,2	52,5	23,0	11,2	18,0	10,0	3,5	15 - 20	7,0	70

## WG-BU

Bundlager - Collar Type - Type Épaulement - Tipo Collare - Tipo Collar

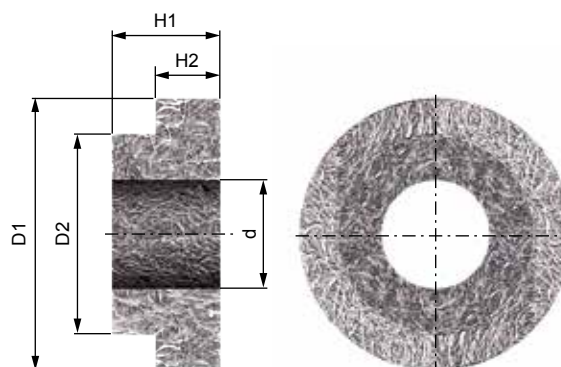

## TECHNISCHE DATEN - SPECIFICATIONS - DONNÉES TECHNIQUES - DATI TECNICI - DATOS TÉCNICOS

	D1	H1	d	D2	H2	Tragkraft - Load - Charge Peso - Carga	Eigenfrequenz - Natural frequency Fréquence propre - Frecuencia propia Frecuencia propia	Einfederung - Static deflection Deformacion - Deflessione statica Deflexion	Gewicht - Weight Poids - Peso Peso
	mm	mm	mm	mm	mm	kN (max.)	Hz	mm	g
WG-BU 17x5,5x8,2	17,0	5,5	8,2	12,7	3,5	0,035	30 - 50	0,2	3
WG-BU 21,3x5,5x10,8	21,3	5,5	10,8	15,5	3,5	0,1	30 - 50	0,6	4
WG-BU 24,5x6,5x13,5	24,5	6,5	13,5	17,8	4,5	0,15	30 - 50	0,7	6
WG-BU 29,6x7,5x17,8	29,6	7,5	17,8	22,7	5,0	0,2	30 - 50	1,6	7
WG-BU 36,6x7,5x21,6	36,6	7,5	21,6	27,8	5,0	0,2	30 - 50	1,7	12

# WG-FL

Flachlager - Rectangular Type - Type Rectangulaire  
 Tipo Rettangolare - Tipo Rectangular

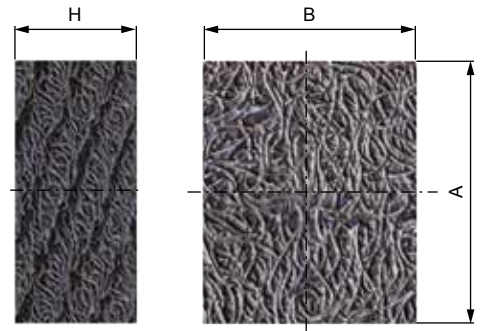

**TECHNISCHE DATEN - SPECIFICATIONS - DONNÉES TECHNIQUES - DATI TECNICI - DATOS TÉCNICOS**

	A	B	H	Tragkraft - Load - Charge Peso - Carga	Eigenfrequenz - Natural frequency Fréquence propre - Frecuencia propia Frecuencia propia	Einfederung - Static deflection Deformacion - Deflessione statica Deflexion	Gewicht - Weight Poids - Peso Peso
	mm	mm	mm	kN (max.)	Hz	mm	g
WG-FL 27,5x27,5x15,5	27,5	27,5	15,5	5,0	15 - 30	2,5	15
WG-FL 29x29x15,5	29,0	29,0	15,5	1,5	15 - 30	4,5	17
WG-FL 46x37,5x21,5	46,0	37,5	21,5	12,5	15 - 30	3,2	60
WG-FL 60,5x31x11	60,5	31,0	11,0	2,5	15 - 30	4,0	35

# WG-FB

Flachlager mit Befestigungsloch - Rectangular type for socket head cap screw fixings  
 Type Rectangulaire avec tou de fixation - Tipo rettangolare con foro di fissaggio  
 Tipo rectangular con agujero de fijación

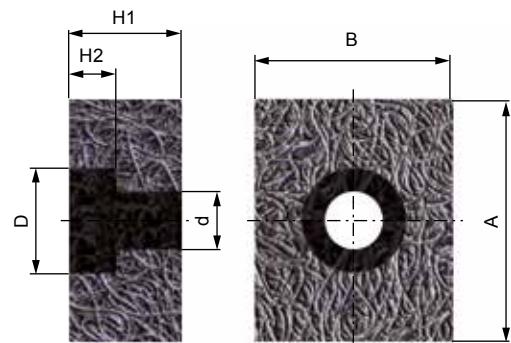

**TECHNISCHE DATEN - SPECIFICATIONS - DONNÉES TECHNIQUES - DATI TECNICI - DATOS TÉCNICOS**

	A	B	H1	d	D	H2	Tragkraft - Load Charge - Peso Carga	Eigenfrequenz - Natural frequency Fréquence propre - Frecuencia propia Frecuencia propia	Einfederung - Static deflection Deformacion - Deflessione statica Deflexion	Gewicht - Weight Poids - Peso Peso
	mm	mm	mm	mm	mm	mm	kN (max.)	Hz	mm	g
WG-FB 29,2x29,2x19x6,4	29,2	29,2	19	6,4	11	8,5	0,75	15 - 20	5,5	22
WG-FB 65x50x25x9	65,0	50,0	25	9,0	20	9,0	5,0	15 - 20	5,2	200



# WG-GI

Metalldämpfer mit Innengewinde - Machine mount type with thread  
 Type Montage Bloc Machine avec Filetage Borne - Tipo macchina con piastra e foro di fissaggio filettato - Tipo montaje maquina con rosca

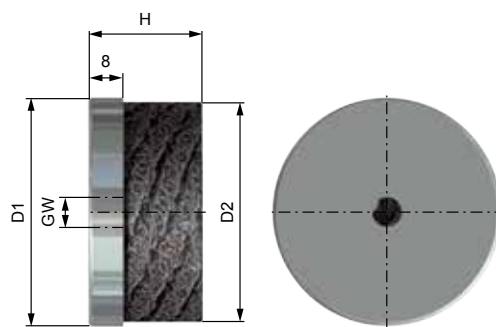

## TECHNISCHE DATEN • SPECIFICATIONS • DONNÉES TECHNIQUES • DATI TECNICI • DATOS TÉCNICOS

	D1	H	D2	GW	Tragkraft - Load - Charge Peso - Carga	Eigenfrequenz - Natural frequency Fréquence propre - Frecuencia propia Frecuencia propia	Einfederung - Static deflection Deformacion - Deflessione statica Deflexion	Gewicht - Weight Poids - Peso Peso
	mm	mm	mm	mm	kN (max.)	Hz	mm	g
WG-GI 28x17,5	28	17,5	23,6	M6	0,6	15 - 20	4,2	20
WG-GI 40x17	40	17,0	34,5	M6	1,0	15 - 20	4,8	40
WG-GI 45x22	45	22,0	40,0	M8	1,5	15 - 20	5,6	60
WG-GI 58x22	58	22,0	53,6	M8	2,25	15 - 20	6,3	100

# WG-LB

Lagerbock - Machine mount type with plate - Type Montage Bloc Machine  
 Tipo macchina con piastra, foro di fissaggio filettato e flangia di fissaggio  
 Tipo montaje máquina con brida

### WG-LB 7710 / 7720

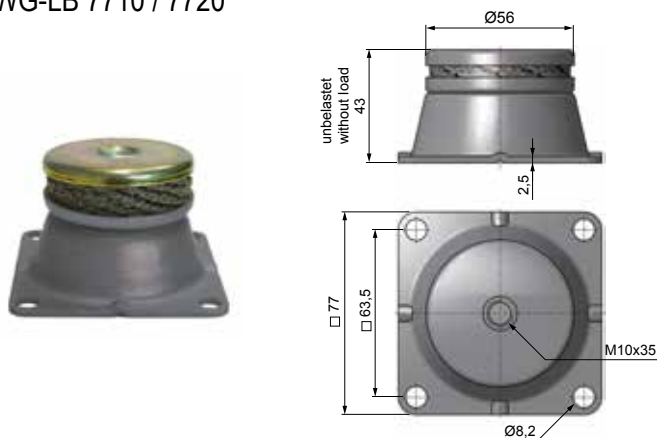

### WG-LB 7750 / 7760



## TECHNISCHE DATEN • SPECIFICATIONS • DONNÉES TECHNIQUES • DATI TECNICI • DATOS TÉCNICOS

	Tragkraft (stat.) - Load (static) Charge (statique) Peso (estático) Carga (estático)	Tragkraft (dyn.) - Load (dynamic) Charge (dynamique)- Peso (dinamico) Carga (dinámica)		Eigenfrequenz - Natural frequency Fréquence propre Frecuencia propia - Frecuencia propia	Gewicht Weight Poids - Peso Peso
	kN (min. - max.)	Druck - Push - Compression Compresione - Compresión (kN)	Zug - Pull - Traction Estensione - Traccion (kN)	Hz	g
WG-LB 7710	0,05 - 0,3	1,5	1,5	15 - 22	180
WG-LB 7720	0,2 - 2,5	12,5	6,0	15 - 22	180
WG-LB 7750	0,25 - 0,6	1,8	0,75	8 - 10	350
WG-LB 7760	0,5 - 1,7	5,1	1,5	8 - 10	350

## Ganzmetalldämpfer

### WG-MB\*



- Kissensitz aus Stahlguss
- Ganzmetallkissen aus rostfreiem CrNi-Stahldraht
- Oberflächenschutz: lackiert
- Resilient elements holder in malleable cast iron
- Resilient element fabricated from stainless steel wire
- Surface protection: painted

### WG-VR / WG-VRD\*



- Vielrichtungsdämpfer
- Kissensitz und Gehäuse aus Stahlguss
- Zugbelastungen können aufgenommen werden
- Multi-directional damper
- Resilient elements holder and housing in malleable cast iron
- Can be used in tension

### WG-MF\*



- Gehäuse und Unterteil aus Stahl
- Achse in hochfester Aluminiumlegierung
- Die Anordnung und Form der Ganzmetallkissen im Dämpfer erlaubt die Aufnahme von hohen Horizontal- und Zugkräften
- Top cup and base: iron
- Centre mounting stud – high strength aluminium alloy
- The arrangement and form of the whole resilient elements in the damper allowed the admission of high horizontal forces and tractive powers

### WG-FVD\*



- Grundplatte mit Dämpfungseinheit und Deckplatte aus Stahl
- Geschlossene Dämpfungseinheit mit hochviskosem Dämpfungsmedium
- Federn aus Federstahldraht
- Base plate with damping unit and cover plate in steel
- Sealed damping unit with highly viscous damping fluid
- Springs in spring steel

### WG-MP\*



- Platte und Kissensitz aus Stahl
- Ganzmetallkissen aus rostfreiem CrNi-Stahldraht
- Verringerung der Eigenfrequenz bei zwei Dämpfungskissen übereinander
- Top cup and base: steel
- Resilient element: stainless steel wire
- Mountings with 2 cushions with low resonant frequency.

### WG-MD\*



- Gehäuse und Unterteil aus Stahlguss
- Die Anordnung der Ganzmetallkissen im Dämpfer erlaubt die Aufnahme von hohen Horizontal- und Zugkräften
- Top cup and base: cast iron
- The arrangement of the whole resilient elements in the damper allowed the admission of high horizontal forces and tractive powers

### WG-DL\*



- Grund- und Deckplatte aus Stahl
- Kissensitze aus Stahlguss
- Verringerung der Eigenfrequenz bei mehreren Dämpfungskissen übereinander
- Die konische Form der im Dämpfer verwendeten Ganzmetallkissen erlaubt auch seitliche Belastbarkeit
- Base plate and cover plate: steel
- Cushion plates: cast iron
- Reduced natural frequency when multiple cushions are stacked
- The arrangement and form of the whole resilient elements in the damper allowed the admission of horizontal forces

### WG-AE\*



- Abspannelement und Zubehör aus Stahl
- Ganzmetallkissen aus rostfreiem CrNi-Stahldraht
- Oberflächenschutz: verzinkt
- Strain element and equipment: steel
- Resilient element: stainless steel wire
- Protection: Zinc plated

WG-RU, -RI, -RL,  
-BU, -FL, FB

WG-MB\*

WG-VR\*

WG-LB

WG-VRD\*

WG-MF\*



Werkzeugmaschinen / Machine Tool	•	•	•	•	•	•
Mobilanlagen / Mobile Systems			•	•	•	•
Klimageräte / Air Conditioners	•			•		
Kompressoren / Compressors	•			•		•
Pumpen / Pumps	•			•		•
Generatoren / Generators			•	•		•
Mühlen / Mills			•		•	•
Abgasleitungen / Exhaust Pipes	•					
Schaltanlagen / Switchboards	•			•		
Transformatoren / Transformers	•		•		•	•
Rohrleitungen / Pipelines	•		•		•	•
Pressen, Scheren Presses, Shears		•	•		•	
Ventilatoren / Fans						
Motoren / Motors	•			•		•
Eigenfrequenz / Natural frequency (Hz)	15 - 40	15 - 40	15 - 30	8-22	15 - 20	15 - 20
Statische Last / Static load(kN)	0,1 - 30	0,5 - 45	0,5 - 70	0,05 - 2,5	0,3 - 9	0,7 - 14
Belastungsrichtung / Loading direction	Druck Push	Druck Push	Druck, Zug Push, Pull	Druck Push	Druck, Zug Push, Pull	Druck, Zug, seittl. Belastung Push, Pull, side load
Abreißsicherung / Breakaway securing			•	•	•	•

WG-FVD\*

WG-MP\*

WG-MD\*

WG-DL\*

WG-AE



Werkzeugmaschinen / Machine Tool		•		•	
Schaltanlagen / Switchboards	•				
Transformatoren / Transformers		•			•
Rohrleitungen / Pipelines			•	•	
Motoren / Motors			•		
empf. Geräte / sensitive Equipment	•				
Klimageräte / Air Conditioners	•				
Siebe / Sieve	•				
Tomographien / Tomography	•				
Textilmaschinen / Textile machinery	•				
Druckmaschinen / Presses	•			•	
Schiffe: Abgasleitungen Ships: exhaust pipes					•
Eigenfrequenz / Natural frequency (Hz)	3 - 4	13-20	18 - 25	9 - 20	9 - 20
Statische Last / Static load(kN)	4 - 32	1,2-70	3,5 - 350	2,5 - 280	10 - 800 kg
Belastungsrichtung / Loading direction	Druck Push	Druck Push	Druck, Zug, seittl. Belastung Push, Pull, side load	Druck Push	Zug Pull
Abreißsicherung / Breakaway securing			•		•

Архангельск (8182)63-90-72  
Астана (7172)727-132  
Астрахань (8512)99-46-04  
Барнаул (3852)73-04-60  
Белгород (4722)40-23-64  
Брянск (4832)59-03-52  
Владивосток (423)249-28-31  
Волгоград (844)278-03-48  
Вологда (8172)26-41-59  
Воронеж (473)204-51-73  
Екатеринбург (343)384-55-89  
Иваново (4932)77-34-06

Ижевск (3412)26-03-58  
Иркутск (395)279-98-46  
Казань (843)206-01-48  
Калининград (4012)72-03-81  
Калуга (4842)92-23-67  
Кемерово (3842)65-04-62  
Киров (8332)68-02-04  
Краснодар (861)203-40-90  
Красноярск (391)204-63-61  
Курск (4712)77-13-04  
Липецк (4742)52-20-81  
Киргизия (996)312-96-26-47

Магнитогорск (3519)55-03-13  
Москва (495)268-04-70  
Мурманск (8152)59-64-93  
Набережные Челны (8552)20-53-41  
Нижний Новгород (831)429-08-12  
Новокузнецк (3843)20-46-81  
Новосибирск (383)227-86-73  
Омск (3812)21-46-40  
Орел (4862)44-53-42  
Оренбург (3532)37-68-04  
Пенза (8412)22-31-16  
Россия (495)268-04-70

Пермь (342)205-81-47  
Ростов-на-Дону (863)308-18-15  
Рязань (4912)46-61-64  
Самара (846)206-03-16  
Санкт-Петербург (812)309-46-40  
Саратов (845)249-38-78  
Севастополь (8692)22-31-93  
Симферополь (3652)67-13-56  
Смоленск (4812)29-41-54  
Сочи (862)225-72-31  
Ставрополь (8652)20-65-13  
Казахстан (772)734-952-31

Сургут (3462)77-98-35  
Тверь (4822)63-31-35  
Томск (3822)98-41-53  
Тула (4872)74-02-29  
Тюмень (3452)66-21-18  
Ульяновск (8422)24-23-59  
Уфа (347)229-48-12  
Хабаровск (4212)92-98-04  
Челябинск (351)202-03-61  
Череповец (8202)49-02-64  
Ярославль (4852)69-52-93