

Архангельск (8182)63-90-72
Астана (7172)727-132
Астрахань (8512)99-46-04
Барнаул (3852)73-04-60
Белгород (4722)40-23-64
Брянск (4832)59-03-52
Владивосток (423)249-28-31
Волгоград (844)278-03-48
Вологда (8172)26-41-59
Воронеж (473)204-51-73
Екатеринбург (343)384-55-89
Иваново (4932)77-34-06

Ижевск (3412)26-03-58
Иркутск (395)279-98-46
Казань (843)206-01-48
Калининград (4012)72-03-81
Калуга (4842)92-23-67
Кемерово (3842)65-04-62
Киров (8332)68-02-04
Краснодар (861)203-40-90
Красноярск (391)204-63-61
Курск (4712)77-13-04
Липецк (4742)52-20-81
Киргизия (996)312-96-26-47

Магнитогорск (3519)55-03-13
Москва (495)268-04-70
Мурманск (8152)59-64-93
Набережные Челны (8552)20-53-41
Нижний Новгород (831)429-08-12
Новокузнецк (3843)20-46-81
Новосибирск (383)227-86-73
Омск (3812)21-46-40
Орел (4862)44-53-42
Оренбург (3532)37-68-04
Пенза (8412)22-31-16
Россия (495)268-04-70

Пермь (342)205-81-47
Ростов-на-Дону (863)308-18-15
Рязань (4912)46-61-64
Самара (846)206-03-16
Санкт-Петербург (812)309-46-40
Саратов (845)249-38-78
Севастополь (8692)22-31-93
Симферополь (3652)67-13-56
Соленск (4812)29-41-54
Сочи (862)225-72-31
Ставрополь (8652)20-65-13
Казахстан (772)734-952-31

Сургут (3462)77-98-35
Тверь (4822)63-31-35
Томск (3822)98-41-53
Тула (4872)74-02-29
Тюмень (3452)66-21-18
Ульяновск (8422)24-23-59
Уфа (347)229-48-12
Хабаровск (4212)92-98-04
Челябинск (351)202-03-61
Череповец (8202)49-02-64
Ярославль (4852)69-52-93

<https://weforma.nt-rt.ru/> || wmb@nt-rt.ru



WN-M 0,1 - 1,0

Notfall · Emergency
Urgence · Emergenza · Emergencia

GB

High energy absorption up to 650 Nm / stroke
Individual adapted deceleration characteristic

Temperature -20°C - +80°C
Option: -50°C - +60°C / 0°C - +120°C
Special models Stainless steel
Pressure chambers up to 7 bar
USDA-H1-compliant for food industry

Order information: WN-M 1,0-XXXX

For the first order technical information for the application is required

F

Absorption d'énergie élevée jusqu'à 650 Nm / course
Caractéristique de décélération personnalisée

Températures -20°C - +80°C
Option: -50°C - +60°C / 0°C - +120°C
Version spéciale INOX
Chambres pressurisées jusqu'à 7 bars
Industrie alimentaire selon USDA-H1

Information pour la commande: WN-M 1,0-XXXX

Les données techniques sont exigées pour la première commande.

I

Assorbimento di energia elevato fino a 650 Nm / corsa
Caratteristica di decelerazione personalizzata

Temperatura -20°C - +80°C
Opz.: -50°C - +60°C / 0°C - +120°C
Versione speciale Acciaio inox
Camera di pressione fino a 7 bar
Industria alimentare secondo
USDA-H1

Informazioni di ordine: WN-M 1,0-XXXX

Per il primo ordine sono richieste informazioni tecniche

E

Absorción de la energía alta hasta 650 Nm / carrera
Característica de la desaceleración individual

Temperaturas -20°C - +80°C
Opz.: -50°C - +60°C / 0°C - +120°C
Edición especial Acero inoxidable
Cámara de presión de hasta 7 bar
Industria alimenticia conforme
a USDA-H1

Información de la orden: WN-M 1,0-XXXX

Para la primera orden se requiere la información técnica

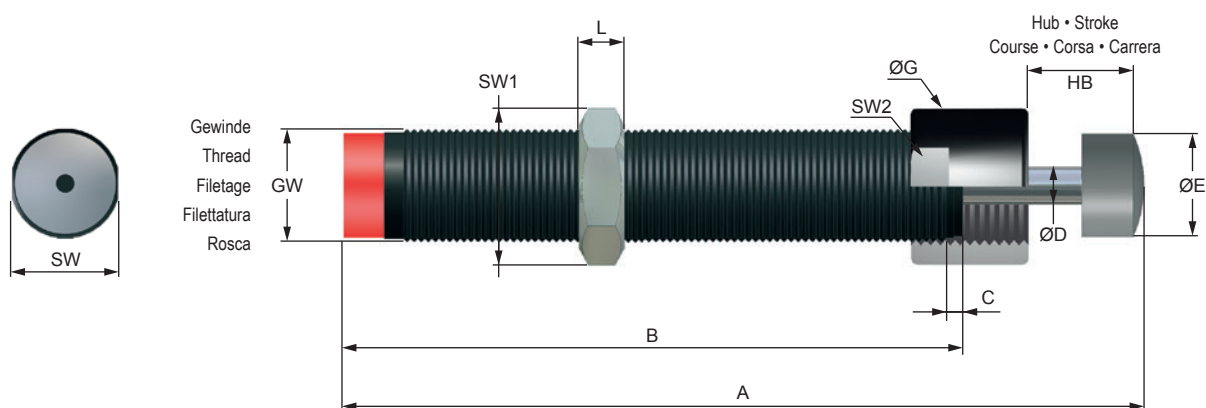

ABMESSUNGEN • DIMENSIONS • DIMENSIONI • DIMENSIONES

	GW	A	B	C	Ø D	Ø E	Ø G	L	SW	SW 1	SW 2
		mm	mm	mm	mm	mm	mm	mm	mm	mm	mm
WN-M 0,1	M 8 x 1,0	57	44,0	2,5	2,5	6,0	11	3	-	11	-
WN-M 0,15	M 10 x 1,0	66	49,5	2,5	3,0	8,5	14	3	-	13	-
WN-M 0,2	M 12 x 1,0	85	65,0	2,5	4,0	10,0	16	4	-	14	-
WN-M 0,25	M 14 x 1,0	100	78,0	2,5	4,0	10,0	18	5	13	17	15
WN-M 0,35	M 16 x 1,0	100	78,0	2,5	4,0	10,0	21	6	14	19	19
WN-M 0,5 x 19	M 20 x 1,0	117	88,0	2,5	6,0	16,0	25	6	18	24	22
WN-M 1,0	M 24 x 1,5	146	108,0	3,5	8,0	20,0	31	8	23	30	30
WN-M 1,0 x 40	M 24 x 1,5	183	130,0	3,5	8,0	20,0	31	8	23	30	30

*Optionale Gewinde: Seite 18/19 - Optional threads: page 18/19 - Filetages facultatifs: page 18/19 - Filetti facoltativi: pagina 18/19 - Rosca opcionales: página 18/19

LEISTUNGEN • PERFORMANCE • CARATTERISTICHE TECNICHE • CARACTERÍSTICAS TÉCNICAS

	Hub Stroke Course Corsa Carrera	Energieaufnahme Energy absorption Energie d'absorption Assorbimento d'energia Absorción de energía	Rückholfederkraft Return spring force Force du ressort Forza di ritorno Fuerza del muelle recuperador	Drehmoment Torque Couple Coppia Par	Gewicht Weight Poids Peso Peso	
	mm	Nm/HB (max.)	min. N	max. N	Nm max.	kg
WN-M 0,1	7	6,0	2,5	6	2	0,01
WN-M 0,15	10	22,5	3,6	8	6	0,02
WN-M 0,2	12	35,0	3,5	7	10	0,036
WN-M 0,25	14	50,0	13,0	23	20	0,05
WN-M 0,35	14	55,0	13,0	23	20	0,07
WN-M 0,5 x 19	19	300,0	12,0	23	25	0,13
WN-M 1,0	25	430,0	15,0	31	30	0,25
WN-M 1,0 x 40	40	650,0	11,0	20	30	0,39

Notfall · Emergency

Urgence · Emergenza · Emergencia



GB

High energy absorption up to 31.200 Nm / stroke Individual adapted deceleration characteristic

Temperature	-20°C - +80°C Option: -50°C - +60°C / 0°C - +120°C
Special models	Stainless steel Pressure chambers up to 7 bar USDA-H1-compliant for food industry

Order information: WN-M 1,25x1-XXXX
For the first order technical information for the application is required

I

Assorbimento di energia elevato fino a 31.200 Nm / corsa Caratteristica di decelerazione personalizzata

Temperatura	-20°C - +80°C Opz.: -50°C - +60°C / 0°C - +120°C
Versione speciale	Acciaio inox Camera di pressione fino a 7 bar Industria alimentare secondo USDA-H1

Informazioni di ordine: WN-M 1,25x1-XXXX
Per il primo ordine sono richieste informazioni tecniche

D

Hohe Energieaufnahme bis 31.200 Nm / Hub Individuelle Dämpfungscharakteristik

Temperaturbereich	-20°C - +80°C Optional: -50°C - +60°C / 0°C - +120°C
Sonderausführungen	Edelstahl Druckraum bis 7 bar Lebensmittelindustrie nach USDA-H1

Bestellbezeichnung: WN-M 1,25x1-XXXX
Für die Erstbestellung benötigen wir die techn. Daten.

F

Absorption d'énergie élevée jusqu'a 31.200 Nm / course Caractéristique de décélération personnalisée

Températures	-20°C - +80°C Option: -50°C - +60°C / 0°C - +120°C
Version spéciale	INOX Chambres pressurisées jusqu'à 7 bars Industrie alimentaire selon USDA-H1

Information pour la commande: WN-M 1,25x1-XXXX
Les données techniques sont exigées pour la première commande.

E

Absorción de la energía alta hasta 31.200 Nm / carrera Característica de la desaceleración individual

Temperaturas	-20°C - +80°C Opc: -50°C - +60°C / 0°C - +120°C
Edición especial	Acero inoxidable Cámara de presión de hasta 7 bar Industria alimenticia conforme a USDA-H1

Información de la orden: WN-M 1,25x1-XXXX
Para la primera orden se requiere la información técnica

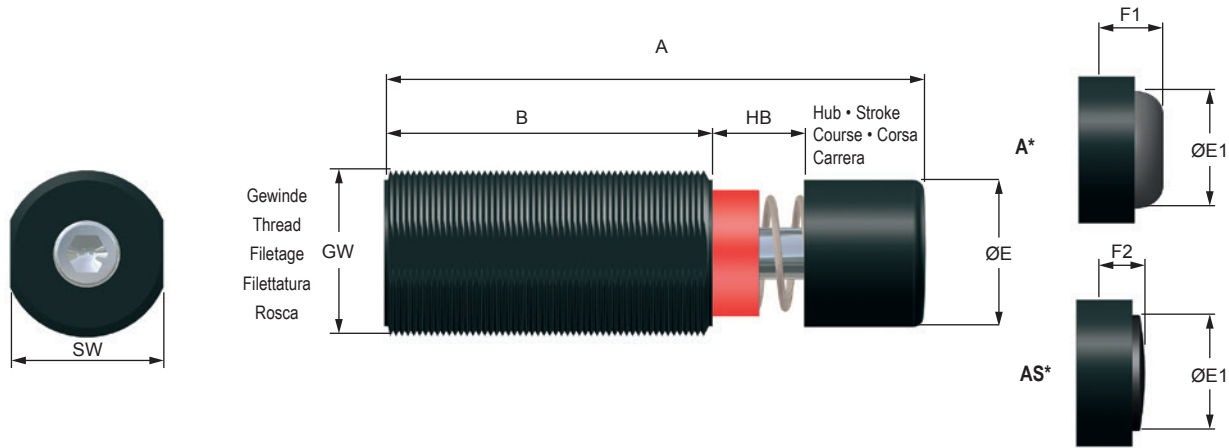

*A: PU / AS: Stahl • Steel • Acier • Acciaio • Acero

"A / AS" zur Artikelbezeichnung hinzufügen - Add "A / AS" after the part no. - À la commande, ajouter la lettre "A / AS" en fin de référence
 Aggiungere la lettera "A / AS" alla fine del codice d'ordine - Añadir la letra „A / AS“ al final de la referencia

ABMESSUNGEN • DIMENSIONS • DIMENSIONI • DIMENSIONES

	GW	A	B	Ø E	Ø E1	F1	F2	SW
		mm	mm	mm	mm	mm	mm	mm
WN-M 1,25 x 1	M 32 x 1,5	138	85	29,0	21	16	12	30
WN-M 1,25 x 2	M 32 x 1,5	188	110	29,0	21	16	12	30
WN-M 1,25 x 3	M 32 x 1,5	243	140	29,0	21	16	12	30
WN-M 1,25 x 4	M 32 x 1,5	306	154	29,0	21	16	12	30
WN-M 1,5 x 1	M 45 x 2	148	89	39,6	31	18	13	41
WN-M 1,5 x 2	M 45 x 2	198	114	39,6	31	18	13	41
WN-M 1,5 x 3	M 45 x 2	248	139	39,6	31	18	13	41
WN-M 2,0 x 1	M 62 x 2	186	104	59,0	49	25	14	60
WN-M 2,0 x 2	M 62 x 2	236	129	59,0	49	25	14	60
WN-M 2,0 x 4	M 62 x 2	336	179	59,0	49	25	14	60
WN-M 2,0 x 6	M 62 x 2	453	246	59,0	49	25	14	60
WN-M 3,0	Abmessungen Seite 52 • Dimensions Page 52 • Dimensioni Pagina 52 • Dimensiones Página 52							

*Optionale Gewinde: Seite 18/19 - Optional threads: page 18/19 - Filetages facultatifs: page 18/19 - Filetti facoltativi: pagina 18/19 - Rosca opcionales: página 18/19

LEISTUNGEN • PERFORMANCE • CARATTERISTICHE TECNICHE • CARACTERÍSTICAS TÉCNICAS

	Hub Stroke Course Corsa Carrera	Energieaufnahme Energy absorption Energie d'absorption Assorbimento d'energia Absorción de energía	Rückholfederkraft Return spring force Force du ressort Forza di ritorno Fuerza del muelle recuperador	Drehmoment Torque Couple Coppia Par	Gewicht Weight Poids Peso Peso	
	mm	Nm/HB (max.)	min. N	max. N	Nm max.	kg
WN-M 1,25 x 1	25	600	30	50	40	0,45
WN-M 1,25 x 2	50	1000	23	50	40	0,55
WN-M 1,25 x 3	75	1200	15	100	40	0,70
WN-M 1,25 x 4	100	1400	23	50	40	0,85
WN-M 1,5 x 1	25	1400	50	70	40	0,95
WN-M 1,5 x 2	50	2500	35	70	40	1,1
WN-M 1,5 x 3	75	3500	35	80	40	1,2
WN-M 2,0 x 1	25	2400	50	130	40	2,0
WN-M 2,0 x 2	50	6000	40	130	40	3,0
WN-M 2,0 x 4	100	12000	45	130	40	3,9
WN-M 2,0 x 6	150	18000	35	130	40	4,8
WN-M 3,0 x 2	50	7000	120	200	-	7,0
WN-M 3,0 x 4	100	15750	120	250	-	9,0
WN-M 3,0 x 6	150	24500	170	250	-	12,0
WN-M 3,0 x 8	200	33250	170	250	-	15,0
WN-M 3,0 x 10	250	42000	170	280	-	20,0

Архангельск (8182)63-90-72
 Астана (7172)727-132
 Астрахань (8512)99-46-04
 Барнаул (3852)73-04-60
 Белгород (4722)40-23-64
 Брянск (4832)59-03-52
 Владивосток (423)249-28-31
 Волгоград (844)278-03-48
 Вологда (8172)26-41-59
 Воронеж (473)204-51-73
 Екатеринбург (343)384-55-89
 Иваново (4932)77-34-06

Ижевск (3412)26-03-58
 Иркутск (395)279-98-46
 Казань (843)206-01-48
 Калининград (4012)72-03-81
 Калуга (4842)92-23-67
 Кемерово (3842)65-04-62
 Киров (8332)68-02-04
 Краснодар (861)203-40-90
 Красноярск (391)204-63-61
 Курск (4712)77-13-04
 Липецк (4742)52-20-81
 Киргизия (996)312-96-26-47

Магнитогорск (3519)55-03-13
 Москва (495)268-04-70
 Мурманск (8152)59-64-93
 Набережные Челны (8552)20-53-41
 Нижний Новгород (831)429-08-12
 Новокузнецк (3843)20-46-81
 Новосибирск (383)227-86-73
 Омск (3812)21-46-40
 Орел (4862)44-53-42
 Оренбург (3532)37-68-04
 Пенза (8412)22-31-16
 Россия (495)268-04-70

Пермь (342)205-81-47
 Ростов-на-Дону (863)308-18-15
 Рязань (4912)46-61-64
 Самара (846)206-03-16
 Санкт-Петербург (812)309-46-40
 Саратов (845)249-38-78
 Севастополь (8692)22-31-93
 Симферополь (3652)67-13-56
 Смоленск (4812)29-41-54
 Сочи (862)225-72-31
 Ставрополь (8652)20-65-13
 Казахстан (772)734-952-31

Сургут (3462)77-98-35
 Тверь (4822)63-31-35
 Томск (3822)98-41-53
 Тула (4872)74-02-29
 Тюмень (3452)66-21-18
 Ульяновск (8422)24-23-59
 Уфа (347)229-48-12
 Хабаровск (4212)92-98-04
 Челябинск (351)202-03-61
 Череповец (8202)49-02-64
 Ярославль (4852)69-52-93