

Архангельск (8182)63-90-72
Астана (7172)727-132
Астрахань (8512)99-46-04
Барнаул (3852)73-04-60
Белгород (4722)40-23-64
Брянск (4832)59-03-52
Владивосток (423)249-28-31
Волгоград (844)278-03-48
Вологда (8172)26-41-59
Воронеж (473)204-51-73
Екатеринбург (343)384-55-89
Иваново (4932)77-34-06

Ижевск (3412)26-03-58
Иркутск (395)279-98-46
Казань (843)206-01-48
Калининград (4012)72-03-81
Калуга (4842)92-23-67
Кемерово (3842)65-04-62
Киров (8332)68-02-04
Краснодар (861)203-40-90
Красноярск (391)204-63-61
Курск (4712)77-13-04
Липецк (4742)52-20-81
Киргизия (996)312-96-26-47

Магнитогорск (3519)55-03-13
Москва (495)268-04-70
Мурманск (8152)59-64-93
Набережные Челны (8552)20-53-41
Нижегород (831)429-08-12
Новокузнецк (3843)20-46-81
Новосибирск (383)227-86-73
Омск (3812)21-46-40
Орел (4862)44-53-42
Оренбург (3532)37-68-04
Пенза (8412)22-31-16
Россия (495)268-04-70

Пермь (342)205-81-47
Ростов-на-Дону (863)308-18-15
Рязань (4912)46-61-64
Самара (846)206-03-16
Санкт-Петербург (812)309-46-40
Саратов (845)249-38-78
Севастополь (8692)22-31-93
Симферополь (3652)67-13-56
Смоленск (4812)29-41-54
Сочи (862)225-72-31
Ставрополь (8652)20-65-13
Казахстан (772)734-952-31

Сургут (3462)77-98-35
Тверь (4822)63-31-35
Томск (3822)98-41-53
Тула (4872)74-02-29
Тюмень (3452)66-21-18
Ульяновск (8422)24-23-59
Уфа (347)229-48-12
Хабаровск (4212)92-98-04
Челябинск (351)202-03-61
Череповец (8202)49-02-64
Ярославль (4852)69-52-93

<https://weforma.nt-rt.ru/> || wmb@nt-rt.ru

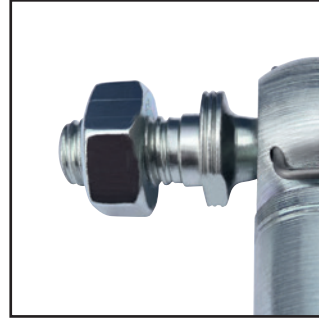
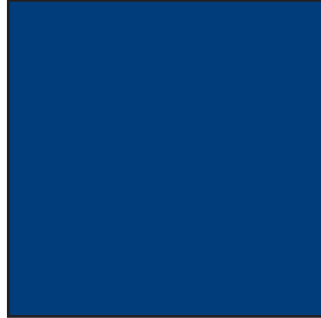
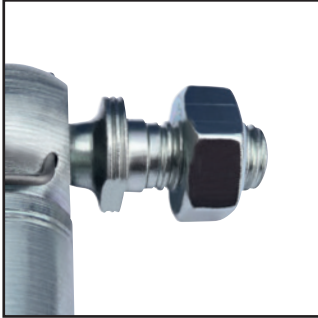

Gasfedern

Gas Springs

Ressorts à Gaz

Molle a Gas

Resortes a Gas



Kraftverlauf · Force diagramme

Forces · Andamento della forza · Evolución de la fuerza

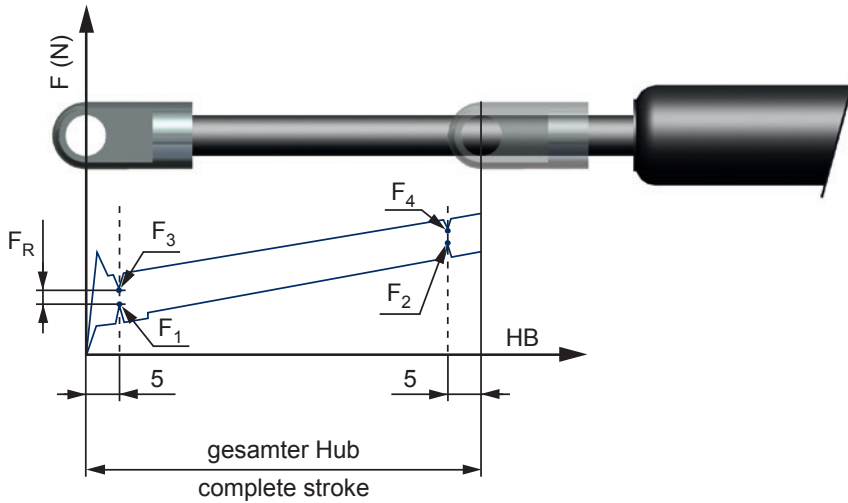

D Kraftverlauf

Die theoretische Ausschubkraft ergibt sich aus Fülldruck x Querschnittsfläche der Kolbenstange. Weforma Gasfedern werden nach Kundenwunsch auf einen bestimmten Druck (Ausschubkraft F_1) gefüllt. Die Ausschubkraft bezieht sich immer auf den Wert F_1 , gemessen bei $20^\circ\text{C} \pm 2^\circ\text{C}$ und bei nach unten weisender Kolbenstange.

- F_1 = Ausschubkraft bei ausgefahrener Kolbenstange
- F_2 = Ausschubkraft bei eingefahrener Kolbenstange
- F_3 = Einschubkraft bei ausgefahrener Kolbenstange
- F_4 = Einschubkraft bei eingefahrener Kolbenstange
- F_R = Reibungskraft

GB Force Diagramme

The theoretical extension force is the result of the filling pressure multiplied by the cross-sectional area of the piston rod. Weforma gas springs are filled to a pressure determined in accordance with the customer's requirements (extension force F_1). The extension force always refers to the value F_1 , measured at $20^\circ\text{C} \pm 2^\circ\text{C}$ and with a downwards facing piston rod.

- F_1 = extension force with extended piston rod
- F_2 = extension force with compressed piston rod
- F_3 = insertion force with extended piston rod
- F_4 = insertion force with compressed piston rod
- F_R = frictional force

F Forces

La force d'extension théorique est calculée en multipliant la pression de remplissage par la superficie de section de la tige de piston. Les ressorts à gaz Weforma sont remplis à une pression définie selon les souhaits du client (force d'extension F_1). La force d'extension se rapporte toujours à la valeur F_1 , mesurée à $20^\circ\text{C} \pm 2^\circ\text{C}$ et avec une tige de piston dirigée vers le bas.

- F_1 = Force d'extension avec tige de piston sortie
- F_2 = Force d'extension avec tige de piston rentrée
- F_3 = Force de compression avec tige de piston sortie
- F_4 = Force de compression avec tige de piston rentrée
- F_R = Force de frottement

I Andamento della forza

La forza di espulsione è uguale alla pressione di riempimento moltiplicata per la superficie della sezione dell' stelo del pistone. Le molle a gas Weforma vengono caricate a una determinata pressione (forza di espulsione F_1) secondo le esigenze del cliente. La forza di espulsione si riferisce sempre al valore F_1 , misurato a $20^\circ\text{C} \pm 2^\circ\text{C}$ con stelo del pistone rivolta verso il basso.

- F_1 = Forza di espulsione con stelo del pistone estratta
- F_2 = Forza di espulsione con stelo del pistone retratta
- F_3 = Forza di inserimento con stelo del pistone estratta
- F_4 = Forza di inserimento con stelo del pistone retratta
- F_R = Forza d'attrito

E Evolución de la fuerza

La fuerza de extracción teórica resulta de la presión de llenado multiplicada por la superficie trasversal de la biela. Los resortes de gas Weforma son rellenos a una presión determinada, por petición del cliente (fuerza de extracción F_1). La fuerza de extracción se basa siempre en el valor F_1 , medido a $20^\circ\text{C} \pm 2^\circ\text{C}$ y con la biela yendo hacia abajo.

- F_1 = Fuerza de extracción con la vástago del émbolo extendida
- F_2 = Fuerza de extracción con la vástago del émbolo contraída
- F_3 = Fuerza de inserción con la vástago del émbolo extendida
- F_4 = Fuerza de inserción con la vástago del émbolo contraída
- F_R = Fuerza de fricción

Progression*
ca. %

WM-G-8	28
WM-G-10	20
WM-G-12	21
WM-G-15	27
WM-G-19	33
WM-G-22	39
WM-G-28	52
WM-G-40	45
WM-G-70	25
WM-GZ-19	20
WM-GZ-28	65

*Progression: linearer Kraftanstieg beim Einfahren bzw. Ausfahren, bemessen von der Nennkraft über den gesamten Hub. Die aufgeführten Werte sind beeinflussbar.

*Progression: linear force increase during extension or compression, measured by the nominal force over the entire stroke. The listed values can be influenced.

*Progression : augmentation linéaire de la force lors de la rentrée ou de la sortie, calculée à partir de la force nominale sur l'ensemble de la course. Les valeurs spécifiées sont soumises à influences.

*Progressione: incremento lineare della forza durante la ritrazione o l'estrazione, misurato dalla forza nominale su tutta la corsa. I valori riportati sono influenzabili.

*Progressión: aumento lineal de la fuerza al entrar o salir, medido de la fuerza nominal sobre todo el desplazamiento. Los valores indicados se pueden ver influidos.

Berechnung · Selection

Donnees de base ▪ Dati di base ▪ Cálculo

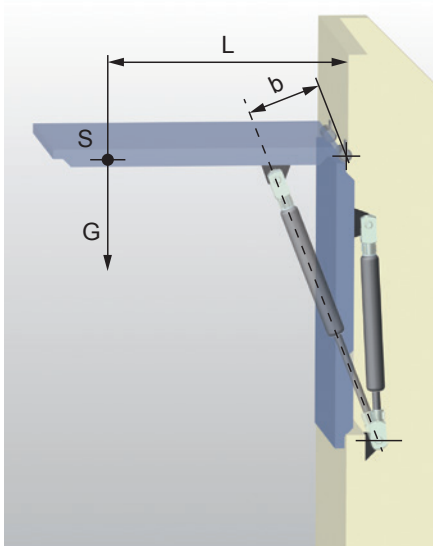

D AUSWAHL

Für die Auswahl bzw. Bestellung sind folgende Angaben notwendig:

S	Schwerpunkt
G	Gewicht der Klappe in N (ca. $K_p \times 10$)
b	Kraftarm (entspricht ca. 85% des erforderlichen Hubs)
X	Anzahl der Federn (in der Regel 2 Stück, pro Klappenseite eine Feder)
L	Radius

Hinweis

Als zulässige Ausschub-Krafttoleranz gilt allgemein +40N - 20N oder $\pm 5-7\%$.

Physikalisch bedingt ist die Kraft einer Gasfeder temperaturabhängig. Sie ändert sich je 10°C um ca. 3,3% (Basis $+20^\circ\text{C}$).

GB SELECTION

For the selection and/or order the following information is required:

S	Centre of gravity
G	Weight of the lid in N (ca. $K_p \times 10$)
b	Lever arm of a force (correlates to approx. 85% of the required stroke)
X	Number of springs (as a rule 2 pieces, one spring each side of the lid)
L	Radius

Note

In general the permitted extended force tolerances are +40N - 20N or $\pm 5-7\%$.

The force of a gas spring is physically dependant on temperature. It varies by approx. 3.3% (basis $+20^\circ\text{C}$) per 10°C .

F SÉLECTION

Pour la sélection et/ou la commande, nous avons besoin des informations suivantes:

S	Point de gravité
G	Poids du capot en N (ca. $K_p \times 10$)
b	Bras de force (correspond à env. 85 % de la course nécessaire)
X	Nombre de ressorts (2 en général, un ressort par côté de clapet)
L	Rayon

Remarque

La tolérance en termes de force d'extension généralement admissible est de +40N - 20N ou $\pm 5-7\%$.

Physiquement, la force d'un ressort à gaz dépend de la température. Elle est modifiée d'env. 3,3 % tous les 10°C (température de base $+20^\circ\text{C}$).

I SELEZIONE

Per la selezione e/o l'eventuale ordine, sono richieste le seguenti informazioni:

S	Baricentro
G	Peso della ribalta in N (ca. $K_p \times 10$)
b	Braccio di forza (corrisponde a ca. l'85% della corsa necessaria)
X	Numero di molle (di norma 2, una molla per ogni lato della ribalta)
L	Raggio

Nota

In generale, la tolleranza ammessa per la forza di espulsione è pari a +40N - 20N o $\pm 5-7\%$.

Per ragioni fisiche la forza di una molla a gas dipende dalla temperatura. Ogni 10°C varia del 3,3% ca. (base $+20^\circ\text{C}$).

E SELECCIÓN

Para la selección o el pedido son necesarios los siguientes datos:

S	Centro de gravedad
G	Peso de la compuerta en N (ca. $K_p \times 10$)
b	Brazo de la fuerza (corresponde a aprox. 85% del desplazamiento necesario)
X	Número de resortes (por lo general 2 uds, por lado de compuerta de un resorte)
L	Radio

Observación

Se considera por lo general la tolerancia de la fuerza de extracción permitida +40N - 20N o $\pm 5-7\%$.

Fisicamente la fuerza de un resorte de gas depende de la temperatura. Se modifica por cada 10°C aprox. 3,3% (base $+20^\circ\text{C}$).

Bestellbeispiel · Ordering Information · Exemple de commande Esempio d'ordinazione · Ejemplo de pedido

WM-G-19-100-K2G4-XXXX-XXXX

WM-G	Gasdruckfedern • Gas Springs • Ressorts à Gaz • Molle a Gas • Resortes a Gas Compression
WM-GZ	Gaszugfedern • Gas traction springs • Ressort à gaz de traction Molle a gas di trazione • Resortes a Gas Tracción
WM-GVA	Gasfedern Edelstahl • Stainless Steel Gas Springs • Ressorts à gaz acier inoxydable Molle a gas acciaio inox • Resortes a Gas acero inoxidable
19	19mm Durchmesser • 19mm diameter • 19mm diamètre • 19mm diametro • 19 mm de diámetro
100	Hub • Stroke • Course • Corsa • Carrera
K0G0	Gewinde • Thread • Filetage • Filettatura • Rosca
K2	Kolbenstange - Winkelgelenk • Piston rod - Angle joint • Tige de piston - Joint à angle Stelo del pistone - Snodo angolare • Vástago del émbolo - charnela articulada
G4	Gehäuse - Gelenkkopf • Housing - Spherical end bearing • Corps - Joint articulé • Corpo - Forcella snodata • Carcasa - charnela macho articulada
Code	Code wird von Weforma bei Bestellung vergeben • Code is assigned by Weforma Code est attribué par Weforma • Codice assegnato dal Weforma • Código es asignado por Weforma



Gasdruckfedern · Gas Springs

Ressorts à Gaz · Molle a Gas · Resortes a Gas Compression



D

Hohe Korrosionsbeständigkeit

- Gehäuse: pulverbeschichtet (WM-G 8: Messing)
- Kolbenstange: keramisch beschichtet (WM-G 8 - 40)
- Kolbenstange hartverchromt (WM-G 70)

Minimale Reibungswerte für niedrigste Ausschubkräfte

Integrierte Fettkammer und Gleitlager

- Niedrige Losbrechkraft
- Einbaulage: beliebig
- Wartungsfrei und einbaufertig
- Temperaturbereich: -30°C – +80°C, optional: -45°C – +200°C
- RoHS konform Richtlinie 2002/95/EG
- Ausschubkraft muss bei Bestellung angegeben werden

GB

High corrosion resistance

- Housing: powder coated (WM-G 8: brass)
- Piston rod: ceramic coated (WM-G 8 - 40)
- Piston rod hard chrome-plated (WM-G 70)

Minimal friction coefficient to achieve the lowest extension forces

Integrated grease chamber and sliding bearing

- Lower breakaway force
- Installation position: any
- Maintenance-free and ready for installation
- Temperature: -30°C – +80°C, optional: -45°C – +200°C
- RoHS compliant Directive 2002/95/EC
- Extension force must be stated on ordering.

F

Résistance élevée à la corrosion

- Corps : peinture à la poudre (WM-G 8 : laiton)
- Tige de piston: revêtement céramique (WM-G 8 - 40)
- Tige de piston revêtue de chrome dur (WM-G 70)

Valeurs de frottement minimales pour atteindre les plus faibles forces d'extension

Chambre de lubrification et palier lisse intégrés

- Faible force de rupture
- Position de montage: au choix
- Sans maintenance et prêt à monter
- Températures: -30°C – +80°C, en option: -45°C – +200°C
- RoHS compliant Directive 2002/95/EC
- L'effort de tarage doit être précisé lors de la commande

I

Elevata resistenza alla corrosione

- Corpo: rivestimento in polvere (WM-G 8: ottone)
- Stelo del pistone: rivestimento ceramico (WM-G 8 - 40)
- Stelo del pistone con riporto in cromo duro (WM-G 70)

Valori d'attrito ridotti per ottenere forze d'espulsione minime

Camera di lubrificazione e cuscinetti a strisciamento integrati

- Forza di spunto ridotta
- Posizione di montaggio: a scelta
- Senza manutenzione e pronte per il montaggio
- Temperatura: -20°C - +80°C, opzionale: -45°C - +200°C
- RoHS compliant Direttiva 2002/95/EC
- La forza di espulsione deve essere indicata quando si effettua l'ordine

E

Alta resistencia a la corrosión

- Carcasa: recubrimiento en polvo (WM-G 8: latón)
- Vástago del émbolo: revestimiento cerámico (WM-G 8 - 40)
- Vástago del émbolo: cromada endurecida (WM-G 70)

Valores de fricción mínimos para conseguir las menores fuerzas de extracción

Cámara de grasa y cojinetes deslizantes integrados

- Fuerza de arranque baja
- Posición de montaje: cualquiera
- Sin mantenimiento y listo para ser montado
- Temperaturas: -30°C – +80°C, opcional: -45°C – +200°C
- RoHS y que cumplan Directiva 2002/95/CE
- Debe indicarse la fuerza de extensión en el pedido

Befestigung / Mounting
Fixation / Fissaggio / Soporte

Befestigung / Mounting
Fixation / Fissaggio / Soporte

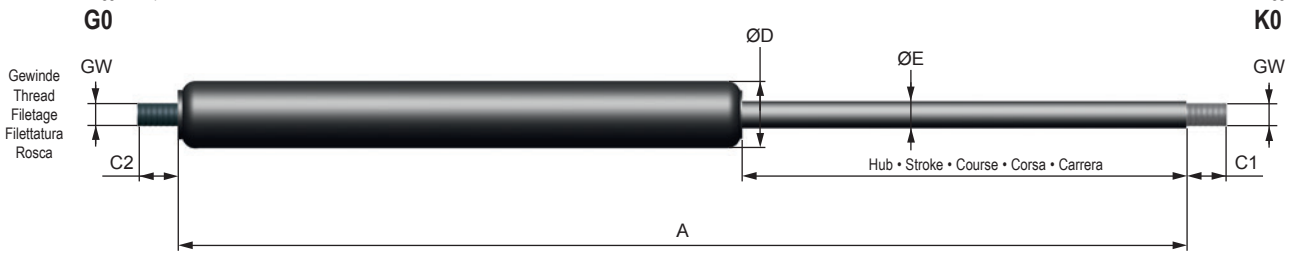

Bestellbeispiel: Seite 227 • Ordering Information: Page 227 • Exemple de commande: page: 227
Esempio d'ordinazione: pagina: 227 • Ejemplo de pedido: página 227

1 Gelenkauge • Male rod clevis
Tête de chape (male)
Attacco a cerniera maschio
Charnela macho

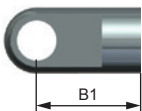

2 Winkelgelenk • Angle joint
Joint à angle • Snodo angolare
Charnela articulada

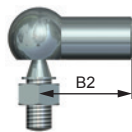

3 Gabelkopf • Female rod clevis
Embout à rotule (femelle)
Forcella femmina
Charnela hembra

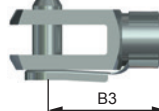

4 Gelenkkopf • Spherical end bearing
Joint articulé • Forcella snodata
Charnela macho articulada

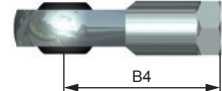

5 Kugelfanne • Ball joint housing
Cousinet sphérique
Cuscinetto sferico
Cojnete esférico

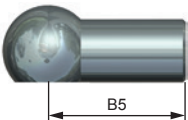

6 nur G
only G
Ablafschraube • Release screw
Vis de purge • Tappo di scarico
Tornillo de vaciado

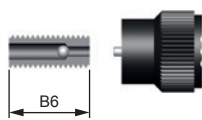

7 Gelenkschraube • Ball joints
Inline rotule • Snodo Sferico Assiale
Línea de rótulas

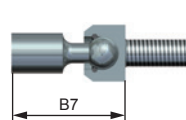

8 Schutzrohr • Protection tube
Tube de protection
Tubo di protezione
Tubo de protección



ABMESSUNGEN • DIMENSIONS • DIMENSIONI • DIMENSIONES

	ø D	Hub • Stroke Course • Corsa Carrera	Kraft • Force Force • Forza Fuerza		Kraft bei eingefahrener Kolbenstange Force with compressed piston rod*	A	B1	B2	B3	B4	B5	B6	B7	C1	C2	ø E	GW
	mm	mm	N min.	N max.	N max.	mm	mm	mm	mm	mm	mm	mm	mm	mm	mm	mm	mm
WM-G-8-20	8	20	10	100	128	72	11	18	16	21	18	-	-	4	4	3	M3
WM-G-8-30	8	30	10	100	128	92	11	18	16	21	18	-	-	4	4	3	M3
WM-G-8-40	8	40	10	100	128	112	11	18	16	21	18	-	-	4	4	3	M3
WM-G-8-50	8	50	10	100	128	132	11	18	16	21	18	-	-	4	4	3	M3
WM-G-8-60	8	60	10	100	128	152	11	18	16	21	18	-	-	4	4	3	M3
WM-G-8-80	8	80	10	100	128	192	11	18	16	21	18	-	-	4	4	3	M3
WM-G-10-20	10	20	10	100	120	72	11	18	16	21	18	-	-	4	4	3	M3
WM-G-10-30	10	30	10	100	120	92	11	18	16	21	18	-	-	4	4	3	M3
WM-G-10-40	10	40	10	100	120	112	11	18	16	21	18	-	-	4	4	3	M3
WM-G-10-50	10	50	10	100	120	132	11	18	16	21	18	-	-	4	4	3	M3
WM-G-10-60	10	60	10	100	120	152	11	18	16	21	18	-	-	4	4	3	M3
WM-G-10-80	10	80	10	100	120	192	11	18	16	21	18	-	-	4	4	3	M3
WM-G-12-20	12	20	10	180	218	72	12	18	16	12	18	5	-	5	5	4	M4
WM-G-12-30	12	30	10	180	218	92	12	18	16	12	18	5	-	5	5	4	M4
WM-G-12-40	12	40	10	180	218	112	12	18	16	12	18	5	-	5	5	4	M4
WM-G-12-50	12	50	10	180	218	132	12	18	16	12	18	5	-	5	5	4	M4
WM-G-12-60	12	60	10	180	218	152	12	18	16	12	18	5	-	5	5	4	M4
WM-G-12-80	12	80	10	180	218	192	12	18	16	12	18	5	-	5	5	4	M4
WM-G-12-100	12	100	10	180	218	232	12	18	16	12	18	5	-	5	5	4	M4
WM-G-12-120	12	120	10	180	218	272	12	18	16	12	18	5	-	5	5	4	M4
WM-G-12-150	12	150	10	180	218	332	12	18	16	12	18	5	-	5	5	4	M4
WM-G-15-20	15	20	20	400	508	67	16	22	20	30	22	5	28	5	5	6	M5
WM-G-15-40	15	40	20	400	508	107	16	22	20	30	22	5	28	5	5	6	M5
WM-G-15-50	15	50	20	400	508	127	16	22	20	30	22	5	28	5	5	6	M5
WM-G-15-60	15	60	20	400	508	147	16	22	20	30	22	5	28	5	5	6	M5
WM-G-15-80	15	80	20	400	508	187	16	22	20	30	22	5	28	5	5	6	M5
WM-G-15-100	15	100	20	400	508	227	16	22	20	30	22	5	28	5	5	6	M5
WM-G-15-120	15	120	20	400	508	267	16	22	20	30	22	5	28	5	5	6	M5
WM-G-15-150	15	150	20	400	508	327	16	22	20	30	22	5	28	5	5	6	M5
WM-G-15-200	15	200	20	400	508	427	16	22	20	30	22	5	28	5	5	6	M5

* Force avec tige de piston rentrée • Forza con stelo del pistone retratta • Fuerza con vástago del émbolo introducida

Befestigung / Mounting
Fixation / Fissaggio / Soporte

Befestigung / Mounting
Fixation / Fissaggio / Soporte

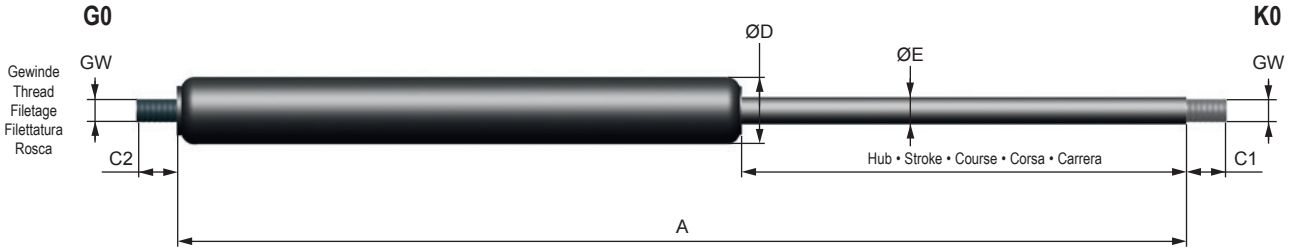

Bestellbeispiel: Seite 227 • Ordering Information: Page 227 • Exemple de commande: page: 227
Esempio d'ordinazione: pagina: 227 • Ejemplo de pedido: página 227

1 Gelenkauge • Male rod clevis
Tête de chape (male)
Attacco a cerniera maschio
Charnela macho

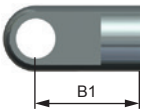

2 Winkelgelenk • Angle joint
Joint à angle • Snodo angolare
Charnela articulada

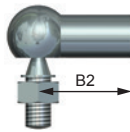

3 Gabelkopf • Female rod clevis
Embout à rotule (femelle)
Forcella femmina
Charnela hembra

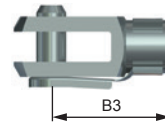

4 Gelenkkopf • Spherical end bearing
Joint articulé • Forcella snodata
Charnela macho articulada

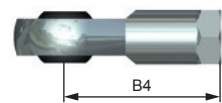

5 Kugelfanne • Ball joint housing
Cousinnet sphérique
Cuscinetto sferico
Cojinete esférico

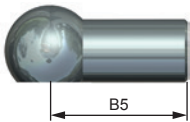

6 nur G
only G
Ablaßschraube • Release screw
Vis de purge • Tappo di scarico
Tornillo de vaciado

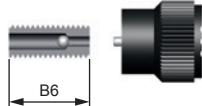

7 Gelenkschraube • Ball joints
Inline rotule • Snodo Sferico Assiale
Linea de rótulas

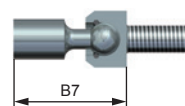

8 Schutzrohr • Protection tube
Tube de protection
Tubo di protezione
Tubo de protección



ABMESSUNGEN • DIMENSIONS • DIMENSIONI • DIMENSIONES

	Ø D	Hub • Stroke Course • Corsa Carrera	Kraft • Force Force • Forza Fuerza		Kraft bei eingefahrener Kolbenstange Force with compressed piston rod*	A	B1	B2	B3	B4	B5	B6	B7	C1	C2	ø E	GW
	mm	mm	N min.	N max.	N max.	mm	mm	mm	mm	mm	mm	mm	mm	mm	mm	mm	mm
WM-G-19-50	19	50	50	700	931	164	20	30	32	36	30	8	31	9	8	8	M8
WM-G-19-100	19	100	50	700	931	264	20	30	32	36	30	8	31	9	8	8	M8
WM-G-19-150	19	150	50	700	931	364	20	30	32	36	30	8	31	9	8	8	M8
WM-G-19-200	19	200	50	700	931	464	20	30	32	36	30	8	31	9	8	8	M8
WM-G-19-250	19	250	50	700	931	564	20	30	32	36	30	8	31	9	8	8	M8
WM-G-19-300	19	300	50	700	931	664	20	30	32	36	30	8	31	9	8	8	M8
WM-G-22-50	22	50	80	1300	1807	164	20	30	32	36	30	8	31	9	8	10	M8
WM-G-22-100	22	100	80	1300	1807	264	20	30	32	36	30	8	31	9	8	10	M8
WM-G-22-150	22	150	80	1300	1807	364	20	30	32	36	30	8	31	9	8	10	M8
WM-G-22-200	22	200	80	1300	1807	464	20	30	32	36	30	8	31	9	8	10	M8
WM-G-22-250	22	250	80	1300	1807	564	20	30	32	36	30	8	31	9	8	10	M8
WM-G-22-300	22	300	80	1300	1807	664	20	30	32	36	30	8	31	9	8	10	M8
WM-G-22-350	22	350	80	1300	1807	764	20	30	32	36	30	8	31	9	8	10	M8
WM-G-22-400	22	400	80	1300	1807	864	20	30	32	36	30	8	31	9	8	10	M8
WM-G-22-450	22	450	80	1300	1807	964	20	30	32	36	30	8	31	9	8	10	M8
WM-G-22-500	22	500	80	1300	1807	1064	20	30	32	36	30	8	31	9	8	10	M8
WM-G-22-550	22	550	80	1300	1807	1164	20	30	32	36	30	8	31	9	8	10	M8
WM-G-22-600	22	600	80	1300	1807	1264	20	30	32	36	30	8	31	9	8	10	M8
WM-G-22-650	22	650	80	1300	1807	1364	20	30	32	36	30	8	31	9	8	10	M8
WM-G-22-700	22	700	80	1300	1807	1464	20	30	32	36	30	8	31	9	8	10	M8
WM-G-28-100	28	100	150	2500	3800	262	25	35	40	43	35	13	-	9	13	14	M10
WM-G-28-150	28	150	150	2500	3800	362	25	35	40	43	35	13	-	9	13	14	M10
WM-G-28-200	28	200	150	2500	3800	462	25	35	40	43	35	13	-	9	13	14	M10
WM-G-28-250	28	250	150	2500	3800	562	25	35	40	43	35	13	-	9	13	14	M10
WM-G-28-300	28	300	150	2500	3800	662	25	35	40	43	35	13	-	9	13	14	M10
WM-G-28-350	28	350	150	2500	3800	762	25	35	40	43	35	13	-	9	13	14	M10
WM-G-28-400	28	400	150	2500	3800	862	25	35	40	43	35	13	-	9	13	14	M10
WM-G-28-450	28	450	150	2500	3800	962	25	35	40	43	35	13	-	9	13	14	M10
WM-G-28-500	28	500	150	2500	3800	1062	25	35	40	43	35	13	-	9	13	14	M10
WM-G-28-550	28	550	150	2500	3800	1162	25	35	40	43	35	13	-	9	13	14	M10
WM-G-28-600	28	600	150	2500	3800	1262	25	35	40	43	35	13	-	9	13	14	M10
WM-G-28-650	28	650	150	2500	3800	1362	25	35	40	43	35	13	-	9	13	14	M10
WM-G-28-700	28	700	150	2500	3800	1462	25	35	40	43	35	13	-	9	13	14	M10
WM-G-28-750	28	750	150	2500	3800	1562	25	35	40	43	35	13	-	9	13	14	M10

* Force avec tige de piston rentrée • Forza con stelo del pistone retratta • Fuerza con vástago del émbolo introducida

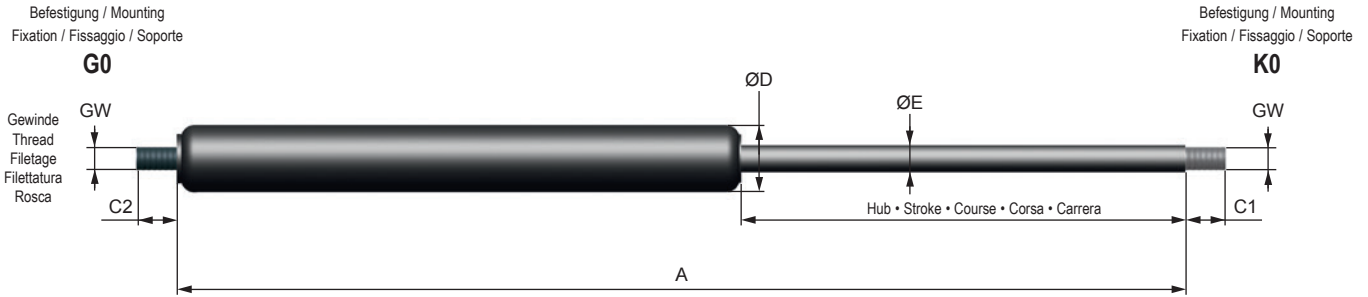

Bestellbeispiel: Seite 227 • Ordering Information: Page 227 • Exemple de commande: page: 227
 Esempio d'ordinazione: pagina: 227 • Ejemplo de pedido: página 227

1 Gelenkauge • Male rod clevis
 Tête de chape (male)
 Attacco a cerniera maschio
 Charnela macho

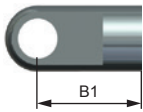

2 Winkelgelenk • Angle joint
 Joint à angle • Snodo angolare
 Charnela articulada

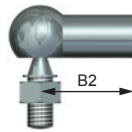

3 Gabelkopf • Female rod clevis
 Embout à rotule (femelle)
 Forcella femmina
 Charnela hembra

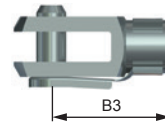

4 Gelenkkopf • Spherical end bearing
 Joint articulé • Forcella snodata
 Charnela macho articulada

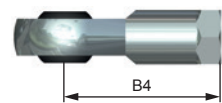

6 nur G
 only G
 Ablaßschraube • Release screw
 Vis de purge • Tappo di scarico
 Tornillo de vaciado

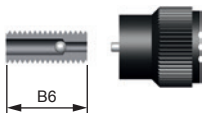

7 Gelenkschraube • Ball joints
 Inline rotule • Snodo Sferico Assiale
 Línea de rótulas

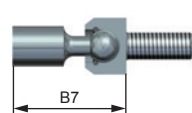

8 Schutzrohr • Protection tube
 Tube de protection
 Tubo di protezione
 Tubo de protección



ABMESSUNGEN • DIMENSIONS • DIMENSIONI • DIMENSIONES

	ø D	Hub • Stroke Course • Corsa Carrera	Kraft • Force Force • Forza Fuerza		Kraft bei eingefahrener Kolbenstange Force with compressed piston rod*	A	B1	B2	B3	B4	B6	B7	C1	C2	ø E	GW
	mm	mm	N min.	N max.	N max.	mm	mm	mm	mm	mm	mm	mm	mm	mm	mm	mm
WM-G-40-100	40	100	500	5000	7250	317	40	45	56	57	15	-	15	15	20	M14x1,5
WM-G-40-150	40	150	500	5000	7250	417	40	45	56	57	15	-	15	15	20	M14x1,5
WM-G-40-200	40	200	500	5000	7250	517	40	45	56	57	15	-	15	15	20	M14x1,5
WM-G-40-300	40	300	500	5000	7250	717	40	45	56	57	15	-	15	15	20	M14x1,5
WM-G-40-400	40	400	500	5000	7250	917	40	45	56	57	15	-	15	15	20	M14x1,5
WM-G-40-500	40	500	500	5000	7250	1117	40	45	56	57	15	-	15	15	20	M14x1,5
WM-G-40-600	40	600	500	5000	7250	1317	40	45	56	57	15	-	15	15	20	M14x1,5
WM-G-40-800	40	800	500	5000	7250	1717	40	45	56	57	15	-	15	15	20	M14x1,5
WM-G-40-1000	40	1000	500	5000	7250	2117	40	45	56	57	15	-	15	15	20	M14x1,5
WM-G-70-100	70	100	2000	12000	15000	320	-	-	100	94	-	-	35	35	30	M24x2,0
WM-G-70-200	70	200	2000	12000	15000	520	-	-	100	94	-	-	35	35	30	M24x2,0
WM-G-70-300	70	300	2000	12000	15000	720	-	-	100	94	-	-	35	35	30	M24x2,0
WM-G-70-400	70	400	2000	12000	15000	920	-	-	100	94	-	-	35	35	30	M24x2,0
WM-G-70-500	70	500	2000	12000	15000	1120	-	-	100	94	-	-	35	35	30	M24x2,0
WM-G-70-600	70	600	2000	12000	15000	1320	-	-	100	94	-	-	35	35	30	M24x2,0
WM-G-70-700	70	700	2000	12000	15000	1520	-	-	100	94	-	-	35	35	30	M24x2,0
WM-G-70-800	70	800	2000	12000	15000	1720	-	-	100	94	-	-	35	35	30	M24x2,0

* Force avec tige de piston rentrée • Forza con stelo del pistone retracts • Fuerza con vástago del émbolo introducida

WM-G-28: Höhere Ausschubkräfte bis 6400 N mit Elasto-Fluid Feder WES-G möglich: Seite 154
 WM-G-28: Higher extension forces up to 6400 N possible using Elasto-Fluid-Springs WES-G: Page 154

Edelstahl Gasfedern · Stainless Steel Gas Springs

Ressorts à gaz acier inoxydable · Molle a gas acciaio inox

Resortes a Gas acero inoxidable



D

Material

Einbaulage
Füllmedium
Temperaturbereich
RoHS konform

Einsatzgebiete

**Gehäuse, Kolbenstange
hochwertiges Niro Material
(V4A, AISI Nr 316L)**

Empfehlung: Kolbenstange nach unten
Stickstoff-Öl
-30°C – +80°C
Richtlinie 2002/95/EG

**Lebensmittelindustrie, Chemie,
Seewasser**

GB

Material

**Housing, Piston rod
high-quality stainless steel
(V4A, AISI No. 316L)**

Installation position Recommendation: piston rod downwards

Filling medium Nitrogen oil
Temperature -30°C – +80°C

RoHS compliant Directive 2002/95/EC

Applications Food industry, Chemicals, Seawater

F

Matériau

**Corps, Tige de piston
Niro de qualité supérieure
(V4A, AISI Nr 316L)**

Position de montage Recommandation : tige de piston vers le bas

Liquide de remplissage Azote-huile
Températures -30°C – +80°C

RoHS compliant Directive 2002/95/EC

**Applications Industrie alimentaire, chimie,
eaux de mer**

I

Materiale

**Corpo, Stelo del pistone
Inossidabile di alta qualità
(V4A, num. AISI 316L)**

Posizione di montaggio Consiglio: stelo del pistone rivolta verso il basso

Fluido di riempimento Azoto-olio
Temperatura -30°C – +80°C

RoHS compliant Direttiva 2002/95/CE

**Applicazioni Industria alimentare, chimica,
acqua di mare**

E

Material

**Carcasa, Vástago del émbolo
Inoxidable de alta calidad
(V4A, AISI Nº 316L)**

Posición de montaje Recomendación: vástago del émbolo hacia abajo

Medio de relleno Aceite de nitrógeno
Temperaturas -30°C – +80°C

RoHS y que cumplan Directiva 2002/95/CE

**Aplicaciones Industria alimentaria, industria
química, agua marina**

G0

K0

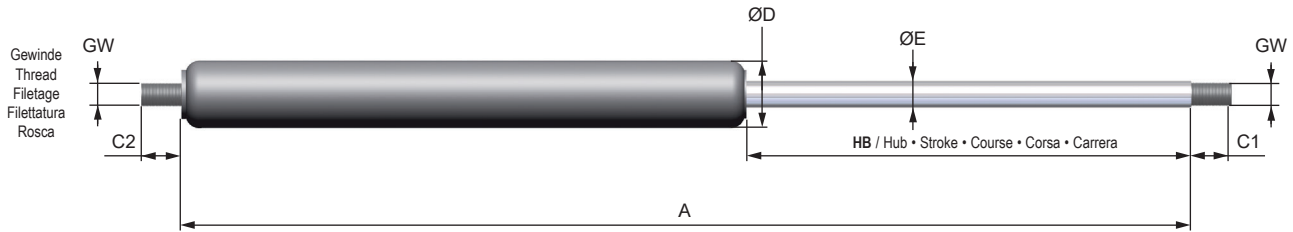

Bestellbeispiel: Seite 227 • Ordering Information: Page 227 • Exemple de commande: page: 227
Esempio d'ordinazione: pagina: 227 • Ejemplo de pedido: página 227

- 1** Gelenkauge • Male rod clevis
Tête de chape (male)
Attacco a cerniera maschio
Charnela macho

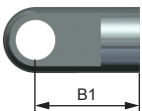

- 2** Winkelgelenk • Angle joint
Joint à angle • Snodo angolare
Charnela articulada

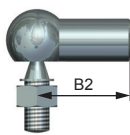

- 3** Gabelkopf • Female rod clevis
Embout à rotule (femelle)
Forcella femmina
Charnela hembra

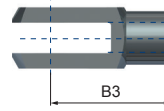

- 4** Gelenkkopf • Spherical end bearing
Joint articulé • Forcella snodata
Charnela macho articulada

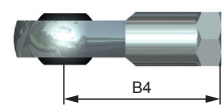

- 5** Kugelpfanne • Ball joint housing
Cousinet sphérique
Cuscinetto sferico
Cojinete esférico

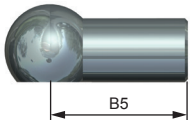

- 6** nur G
Ablafschraube • Release screw
Vis de purge • Tappo di scarico
Tornillo de vaciado

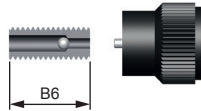

ABMESSUNGEN - DIMENSIONS - DIMENSIONI - DIMENSIONES

	ø D	Hub • Stroke Course • Corsa Carrera	Kraft • Force Force • Forza Fuerza		Kraft bei eingefahrener Kolbenstange Force with compressed piston rod*	A	B1	B2	B3	B4	B5	B6	C1	C2	ø E	GW
	mm	mm	N min.	N max.	N max.	mm	mm	mm	mm	mm	mm	mm	mm	mm	mm	mm
WM-GVA-15-20	15	20	20	400	508	67	16	-	-	-	5	5	5	5	6	M5
WM-GVA-15-40	15	40	20	400	508	107	16	-	-	-	5	5	5	5	6	M5
WM-GVA-15-50	15	50	20	400	508	127	16	-	-	-	5	5	5	5	6	M5
WM-GVA-15-60	15	60	20	400	508	147	16	-	-	-	5	5	5	5	6	M5
WM-GVA-15-80	15	80	20	400	508	187	16	-	-	-	5	5	5	5	6	M5
WM-GVA-15-100	15	100	20	400	508	227	16	-	-	-	5	5	5	5	6	M5
WM-GVA-15-120	15	120	20	400	508	267	16	-	-	-	5	5	5	5	6	M5
WM-GVA-15-150	15	150	20	400	508	327	16	-	-	-	5	5	5	5	6	M5
WM-GVA-19-50	19	50	50	700	931	164	20	30	32	36	30	8	9	8	8	M8
WM-GVA-19-100	19	100	50	700	931	264	20	30	32	36	30	8	9	8	8	M8
WM-GVA-19-150	19	150	50	700	931	364	20	30	32	36	30	8	9	8	8	M8
WM-GVA-19-200	19	200	50	700	931	464	20	30	32	36	30	8	9	8	8	M8
WM-GVA-19-250	19	250	50	700	931	564	20	30	32	36	30	8	9	8	8	M8
WM-GVA-19-300	19	300	50	700	931	664	20	30	32	36	30	8	9	8	8	M8
WM-GVA-22-50	22	50	100	1200	1807	164	20	30	32	36	30	10	9	8	10	M8
WM-GVA-22-100	22	100	100	1200	1807	264	20	30	32	36	30	10	9	8	10	M8
WM-GVA-22-150	22	150	100	1200	1807	364	20	30	32	36	30	10	9	8	10	M8
WM-GVA-22-200	22	200	100	1200	1807	464	20	30	32	36	30	10	9	8	10	M8
WM-GVA-22-250	22	250	100	1200	1807	564	20	30	32	36	30	10	9	8	10	M8
WM-GVA-22-300	22	300	100	1200	1807	664	20	30	32	36	30	10	9	8	10	M8
WM-GVA-22-350	22	350	100	1200	1807	764	20	30	32	36	30	10	9	8	10	M8
WM-GVA-22-400	22	400	100	1200	1807	864	20	30	32	36	30	10	9	8	10	M8
WM-GVA-22-450	22	450	100	1200	1807	964	20	30	32	36	30	10	9	8	10	M8
WM-GVA-22-500	22	500	100	1200	1807	1064	20	30	32	36	30	10	9	8	10	M8
WM-GVA-22-550	22	550	100	1200	1807	1164	20	30	32	36	30	10	9	8	10	M8
WM-GVA-22-600	22	600	100	1200	1807	1264	20	30	32	36	30	10	9	8	10	M8
WM-GVA-22-650	22	650	100	1200	1807	1364	20	30	32	36	30	10	9	8	10	M8
WM-GVA-22-700	22	700	100	1200	1807	1464	20	30	32	36	30	10	9	8	10	M8

* Force avec tige de piston rentrée • Forza con stelo del pistone retracts • Fuerza con vástago del émbolo introducida



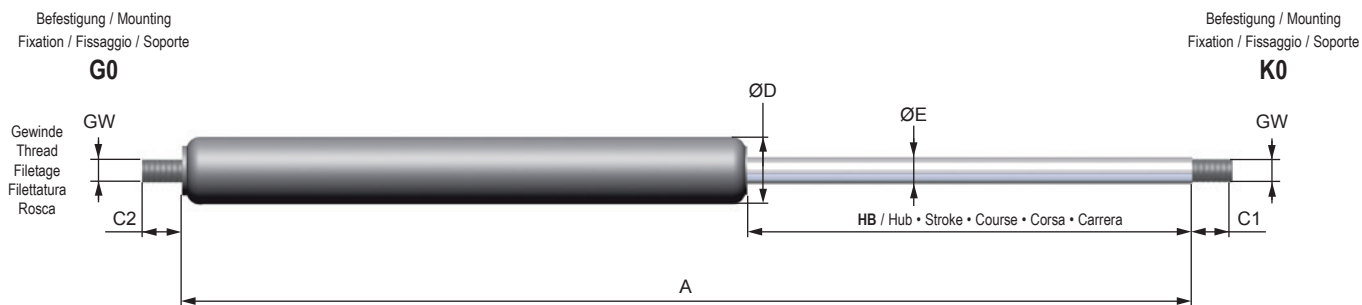

Bestellbeispiel: Seite 227 • Ordering Information: Page 227 • Exemple de commande: page: 227
 Esempio d'ordinazione: pagina: 227 • Ejemplo de pedido: página 227

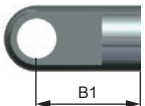
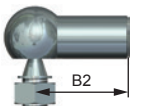
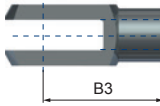
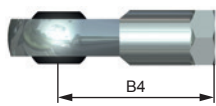
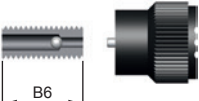
- 1** Gelenkauge • Male rod clevis
 Tête de chape (male)
 Attacco a cerniera maschio
 Charnela macho
 
- 2** Winkelgelenk • Angle joint
 Joint à angle • Snodo angolare
 Charnela articulada
 
- 3** Gabelkopf • Female rod clevis
 Embout à rotule (femelle)
 Forcella femmina
 Charnela hembra
 
- 4** Gelenkkopf • Spherical end bearing
 Joint articulé • Forcella snodata
 Charnela macho articulada
 
- 6** nur G
 only G
 Ablaßschraube • Release screw
 Vis de purge • Tappo di scarico
 Tornillo de vaciado
 

ABMESSUNGEN • DIMENSIONS • DIMENSIONI • DIMENSIONES

	Ø D	Hub • Stroke Course • Corsa Carrera	Kraft • Force Force • Forza Fuerza		Kraft bei eingefahrener Kolbenstange Force with compressed piston rod*	A	B1	B2	B3	B4	B6	C1	C2	Ø E	GW
	mm	mm	N min.	N max.	N max.	mm	mm	mm	mm	mm	mm	mm	mm	mm	mm
WM-GVA-28-100	28	100	150	2500	3800	262	25	35	40	43	13	9	13	14	M10
WM-GVA-28-150	28	150	150	2500	3800	362	25	35	40	43	13	9	13	14	M10
WM-GVA-28-200	28	200	150	2500	3800	462	25	35	40	43	13	9	13	14	M10
WM-GVA-28-250	28	250	150	2500	3800	562	25	35	40	43	13	9	13	14	M10
WM-GVA-28-300	28	300	150	2500	3800	662	25	35	40	43	13	9	13	14	M10
WM-GVA-28-350	28	350	150	2500	3800	762	25	35	40	43	13	9	13	14	M10
WM-GVA-28-400	28	400	150	2500	3800	862	25	35	40	43	13	9	13	14	M10
WM-GVA-28-450	28	450	150	2500	3800	962	25	35	40	43	13	9	13	14	M10
WM-GVA-28-500	28	500	150	2500	3800	1062	25	35	40	43	13	9	13	14	M10
WM-GVA-28-550	28	550	150	2500	3800	1162	25	35	40	43	13	9	13	14	M10
WM-GVA-28-600	28	600	150	2500	3800	1262	25	35	40	43	13	9	13	14	M10
WM-GVA-28-650	28	650	150	2500	3800	1362	25	35	40	43	13	9	13	14	M10
WM-GVA-40-100	40	100	500	5000	7250	317	40	45	-	-	15	15	15	20	M14x1,5
WM-GVA-40-150	40	150	500	5000	7250	417	40	45	-	-	15	15	15	20	M14x1,5
WM-GVA-40-200	40	200	500	5000	7250	517	40	45	-	-	15	15	15	20	M14x1,5
WM-GVA-40-300	40	300	500	5000	7250	717	40	45	-	-	15	15	15	20	M14x1,5
WM-GVA-40-400	40	400	500	5000	7250	917	40	45	-	-	15	15	15	20	M14x1,5
WM-GVA-40-500	40	500	500	5000	7250	1117	40	45	-	-	15	15	15	20	M14x1,5
WM-GVA-40-600	40	600	500	5000	7250	1317	40	45	-	-	15	15	15	20	M14x1,5

* Force avec tige de piston rentrée • Forza con stelo del pistone retratta • Fuerza con vástago del émbolo introducida

1 Gelenkauge • Male rod clevis • Tête de chape (male)
Attacco a cerniera maschio • Charnela macho

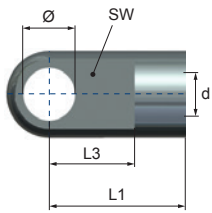

SW	Ø	L1	L3	d	Code	max. N
3	6,2	16	9	M5	1-M5-VA	490
10	8,2	20	20	M8	1-M8-VA	1560
12	8,2	25	12	M10	1-M10-VA	3800
14	14,2	40	20	M14x1,5	1-M14-VA	7000

2 Winkelgelenk • Angle joint • Joint à angle • Snodo angolare • Charnela articulada

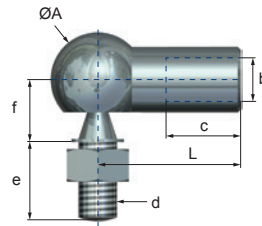

AØ	L	b	c	d	e	f	Code	max. N
13	30	M8	14,5	M8	16,5	13	2-M8-VA	1140
16	35	M10	15,5	M10	20	16	2-M10-VA	1750
19	45	M14x1,5	20	M14x1,5	28	20	2-M14-VA	3200

3 Gabelkopf • Female rod clevis • Embout à rotule (femelle)
Forcella femmina • Charnela hembra

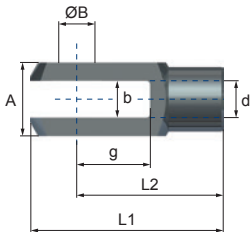

A	ØB	b	g	L1	L2	d	Code	max. N
16	8	8	16	42	32	M8	3-M8-VA	1560
20	10	10	20	52	40	M10	3-M10-VA	3800

4 Gelenkkopf • Spherical end bearing • Joint articulé
Forcella snodata • Charnela macho articulada

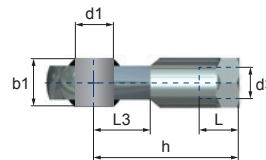

b1	d1	d3	L	L3	h	Code	max. N
8	8	M8	16	12	36	4-M8-VA	1560
9	10	M10	20	13	43	4-M10-VA	3800

5 Kugelpfanne • Ball joint housing • Coussinet sphérique
Cuscinetto sferico • Cojinetes esférico

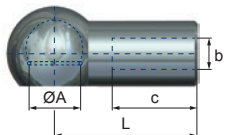

A	L	b	c	Code	max. N
10	19	M8	10	5-M8-2-VA	1140
13	30	M8	14	5-M8-VA	1140

20-VA (für / for 1-M8-VA, 4-M8-VA)

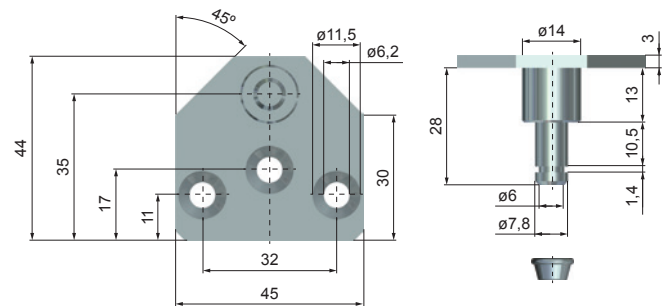

21-VA (für / for 1-M8-VA, 4-M8-VA)

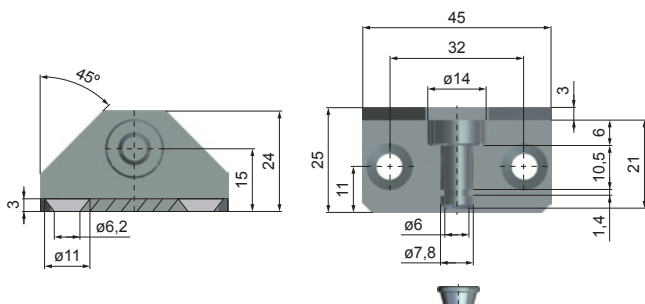

25-VA (für / for 1-M8-VA, 1-M10-VA, 4-M8-VA)

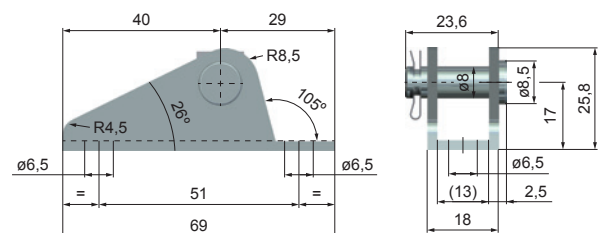

Gaszugfedern · Gas traction springs

Ressorts à gaz de traction · Molle a gas di trazione

Resortes a gas tracción



D

- **Hohe Korrosionsbeständigkeit**
 - Gehäuse: pulverbeschichtet
 - Kolbenstange: keramisch beschichtet
- **Minimale Reibungswerte für niedrigste Ausschubkräfte**
- **Integrierte Fettkammer und Gleitlager**
 - Niedrige Losbrechkraft
 - Einbaulage: beliebig
 - Wartungsfrei und einbaufertig
 - Temperaturbereich: -30°C – +80°C, optional: -45°C – +200°C
 - RoHS konform Richtlinie 2002/95/EG
 - Einzugkraft muss bei Bestellung angegeben werden

GB

- **High corrosion resistance**
 - Housing: powder coated
 - Piston rod: ceramic coated
- **Minimal friction coefficient to achieve the lowest extension forces**
- **Integrated grease chamber and sliding bearing**
 - Lower breakaway force
 - Installation position: any
 - Maintenance-free and ready for installation
 - Temperature: -30°C – +80°C, optional: -45°C – +200°C
 - RoHS compliant Directive 2002/95/EC
 - Pull-in force must be stated on ordering.

F

- **Résistance élevée à la corrosion**
 - Corps : peinture à la poudre
 - Tige de piston: revêtement céramique
- **Valeurs de frottement minimales pour atteindre les plus faibles forces d'extension**
- **Chambre de lubrification et palier lisse intégrés**
 - Faible force de rupture
 - Position de montage : au choix
 - Sans maintenance et prêt à monter
 - Températures: -30°C – +80°C, en option: -45°C – +200°C
 - RoHS compliant Directive 2002/95/EC
 - L'effort d'amortissement doit être précisé lors de la commande

I

- **Elevata resistenza alla corrosione**
 - Corpo: rivestimento in polvere
 - Stelo del pistone: rivestimento ceramico
- **Valori d'attrito ridotti per ottenere forze d'espulsione minime**
- **Camera di lubrificazione e cuscinetti a strisciamento integrati**
 - Forza di spunto ridotta
 - Posizione di montaggio: a scelta
 - Senza manutenzione e pronte per il montaggio
 - Temperatura: -20°C - +80°C, opzionale: -45°C - +200°C
 - RoHS compliant Direttiva 2002/95/EC
 - La forza di inserimento deve essere indicata quando si effettua l'ordine

E

- **Alta resistencia a la corrosión**
 - Carcasa: recubrimiento en polvo
 - Vástago del émbolo: revestimiento cerámico
- **Valores de fricción mínimos para conseguir las menores fuerzas de extracción**
- **Cámara de grasa y cojinetes deslizantes integrados**
 - Fuerza de arranque baja
 - Posición de montaje: cualquiera
 - Sin mantenimiento y listo para ser montado
 - Temperaturas: -30°C – +80°C, opcional: -45°C – +200°C
 - RoHS y que cumplan Directiva 2002/95/CE
 - Debe indicarse la fuerza de inserción en el pedido

G0

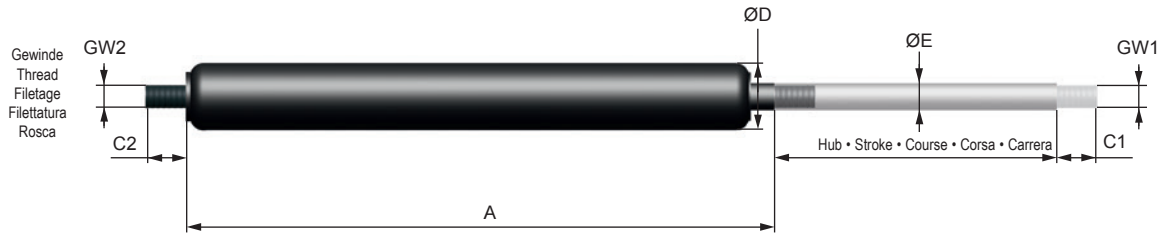

K0

- 1** Gelenkauge • Male rod clevis
Tête de chape (male)
Attacco a cerniera maschio
Charnela macho

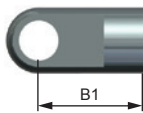

- 2** Winkelgelenk • Angle joint
Joint à angle • Snodo angolare
Charnela articulada

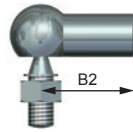

- 3** Gabelkopf • Female rod clevis
Embout à rotule (femelle)
Forcella femmina
Charnela hembra

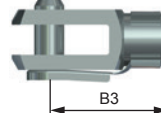

- 4** Gelenkkopf • Spherical end bearing
Joint articulé • Forcella snodata
Charnela macho articulada

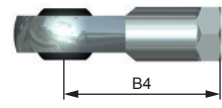

- 5** Kugelpfanne • Ball joint housing
Cousinet sphérique
Cuscinetto sferico
Cojinete esférico

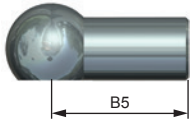

- 6** nur G
only G
Ablafschraube • Release screw
Vis de purge • Tappo di scarico
Tornillo de vaciado

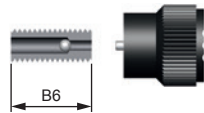

- 8** Schutzrohr • Protection tube
Tube de protection
Tubo di protezione
Tubo de protección



ABMESSUNGEN - DIMENSIONS - DIMENSIONI - DIMENSIONES

	Ø D	Hub • Stroke Course • Corsa Carrera	Kraft • Force Force • Forza Fuerza		Kraft bei ausgezogener Kolbenstange Force with extended piston rod*	A	B1	B2	B3	B4	B5	B6	C1	C2	Ø E	GW1	GW2
	mm	mm	N min.	N max.	N max.	mm	mm	mm	mm	mm	mm	mm	mm	mm	mm	mm	mm
WM-GZ-19-30	19	30	30	300	360	112	20	30	32	36	30	5	10	8	6	M8	M8
WM-GZ-19-50	19	50	30	300	360	132	20	30	32	36	30	5	10	8	6	M8	M8
WM-GZ-19-100	19	100	30	300	360	182	20	30	32	36	30	5	10	8	6	M8	M8
WM-GZ-19-150	19	150	30	300	360	232	20	30	32	36	30	5	10	8	6	M8	M8
WM-GZ-19-200	19	200	30	300	360	282	20	30	32	36	30	5	10	8	6	M8	M8
WM-GZ-28-30	28	30	150	1200	1980	130	25	35	40	43	35	12	9	9	10	M10	M10
WM-GZ-28-50	28	50	150	1200	1980	150	25	35	40	43	35	12	9	9	10	M10	M10
WM-GZ-28-100	28	100	150	1200	1980	200	25	35	40	43	35	12	9	9	10	M10	M10
WM-GZ-28-150	28	150	150	1200	1980	250	25	35	40	43	35	12	9	9	10	M10	M10
WM-GZ-28-200	28	200	150	1200	1980	300	25	35	40	43	35	12	9	9	10	M10	M10
WM-GZ-28-250	28	250	150	1200	1980	350	25	35	40	43	35	12	9	9	10	M10	M10
WM-GZ-28-300	28	300	150	1200	1980	400	25	35	40	43	35	12	9	9	10	M10	M10
WM-GZ-28-350	28	350	150	1200	1980	450	25	35	40	43	35	12	9	9	10	M10	M10
WM-GZ-28-400	28	400	150	1200	1980	500	25	35	40	43	35	12	9	9	10	M10	M10
WM-GZ-28-450	28	450	150	1200	1980	550	25	35	40	43	35	12	9	9	10	M10	M10
WM-GZ-28-500	28	500	150	1200	1980	600	25	35	40	43	35	12	9	9	10	M10	M10
WM-GZ-28-550	28	550	150	1200	1980	650	25	35	40	43	35	12	9	9	10	M10	M10
WM-GZ-28-600	28	600	150	1200	1980	700	25	35	40	43	35	12	9	9	10	M10	M10
WM-GZ-28-650	28	650	150	1200	1980	750	25	35	40	43	35	12	9	9	10	M10	M10

* Force avec tige de piston sortie • Forza con stelo del pistone estratta • Fuerza con vástago del émbolo extendida

M3

1-M3 Gelenkauge • Male rod clevis
Tête de chape (male)
Attacco a cerniera maschio
Charnela macho

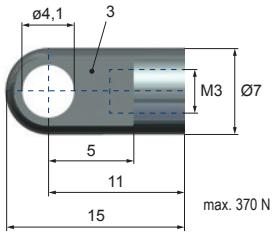

2-M3 Winkelgelenk • Angle joint
Joint à angle • Snodo angolare
Charnela articulada

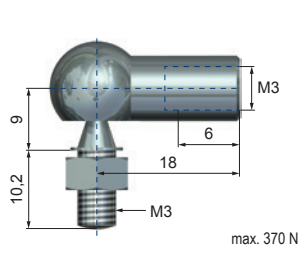

3-M3 Gabelkopf • Female rod clevis
Embout à rotule (femelle)
Forcella femmina
Charnela hembra

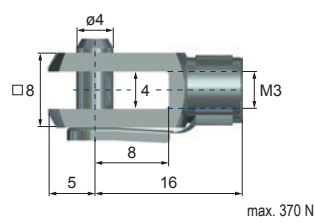

4-M3 Gelenkkopf
Spherical end bearing
Joint articulé • Forcella snodata
Charnela macho articulada

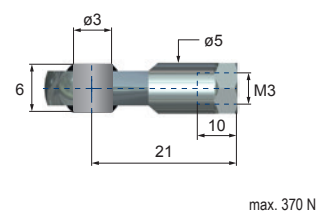

5-M3 Kugelpfanne • Ball joint housing
Cousinet sphérique
Cuscinetto sferico
Cojinete esférico

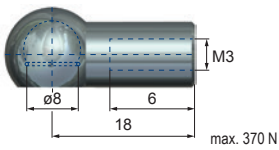

M4

1-M4 Gelenkauge • Male rod clevis
Tête de chape (male)
Attacco a cerniera maschio
Charnela macho

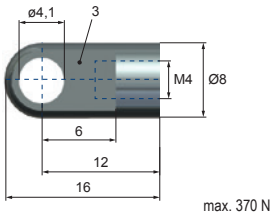

2-M4 Winkelgelenk • Angle joint
Joint à angle • Snodo angolare
Charnela articulada

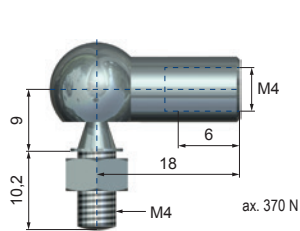

3-M4 Gabelkopf • Female rod clevis
Embout à rotule (femelle)
Forcella femmina
Charnela hembra

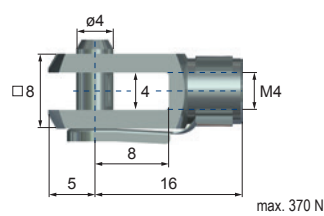

4-M4 Gelenkkopf
Spherical end bearing
Joint articulé • Forcella snodata
Charnela macho articulada

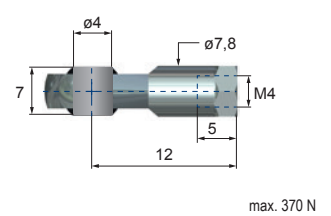

5-M4 Kugelpfanne • Ball joint housing
Cousinet sphérique
Cuscinetto sferico
Cojinete esférico

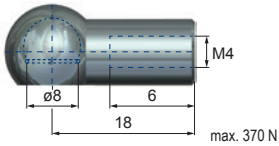

6-M4 Ablaßschraube • Release screw
Vis de purge • Tappo di scarico
Tornillo de vaciado

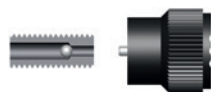

M5

1-M5 Gelenkauge • Male rod clevis
Tête de chape (male)
Attacco a cerniera maschio
Charnela macho

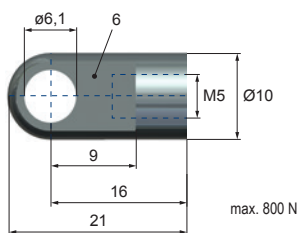

2-M5 Winkelgelenk • Angle joint
Joint à angle • Snodo angolare
Charnela articulada

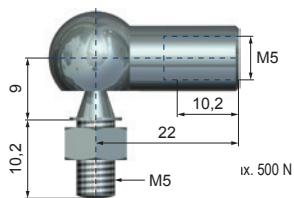

3-M5 Gabelkopf • Female rod clevis
Embout à rotule (femelle)
Forcella femmina
Charnela hembra

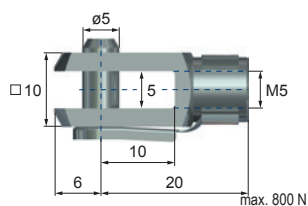

4-M5 Gelenkkopf
Spherical end bearing
Joint articulé • Forcella snodata
Charnela macho articulada

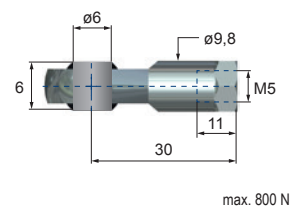

5-M5 Kugelpfanne • Ball joint housing
Cousinet sphérique
Cuscinetto sferico
Cojinete esférico

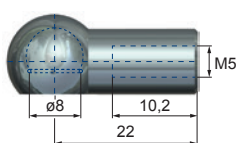

7-M5 Gelenkschraube • Ball joints
In-line rotule • Snodo Sferico Assiale
Línea de rótulas

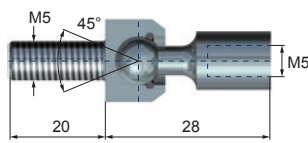

6-15-M5 Ablasschraube • Release screw
Vis de purge • Tappo di scarico
Tornillo de vaciado

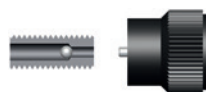

26 (für / for 1-M5, 4-M5)

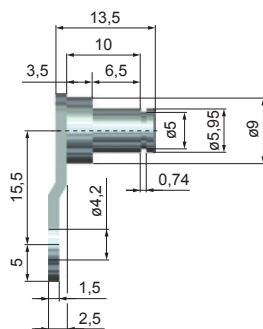
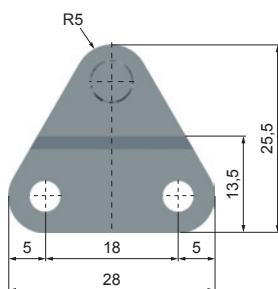

29 (für / for 1-M5, 4-M5)

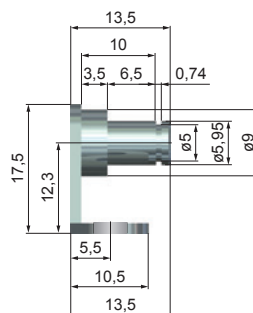
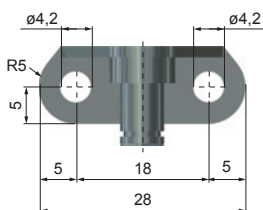
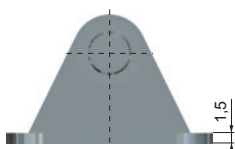

M8

1-M8 Gelenkauge • Male rod clevis
Tête de chape (male)
Attacco a cerniera maschio
Charnela macho

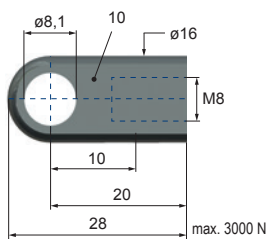

2-M8 Winkelgelenk • Angle joint
Joint à angle • Snodo angolare
Charnela articulada

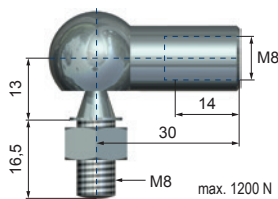

3-M8 Gabelkopf • Female rod clevis
Embout à rotule (femelle)
Forcella femmina
Charnela hembra

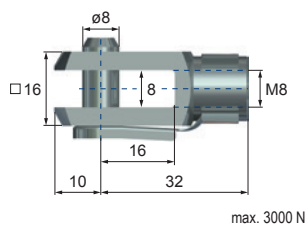

4-M8 Gelenkkopf
Spherical end bearing
Joint articulé • Forcella snodata
Charnela macho articulada

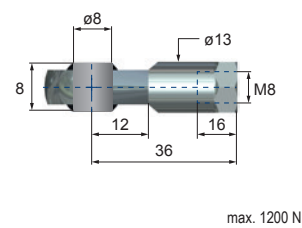

5-M8 Kugelpfanne • Ball joint housing
Coussinet sphérique
Cuscinetto sferico
Cojinete esférico

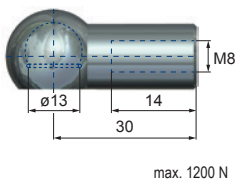

7-M8 Gelensschraube • Ball joints
Inline rotule • Snodo Sferico Assiale
Línea de rótulas

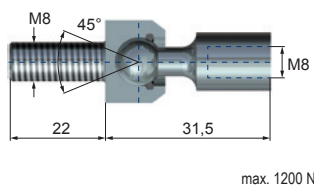

6-22-M8 Ablasschraube • Release screw
Vis de purge • Tappo di scarico
Tornillo de vaciado

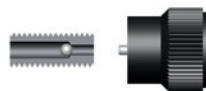

5-2-M8 Kugelpfanne
Ball joint housing
Coussinet sphérique
Cuscinetto sferico
Cojinete esférico

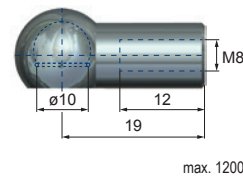

20 (für / for 1-M8, 4-M8)

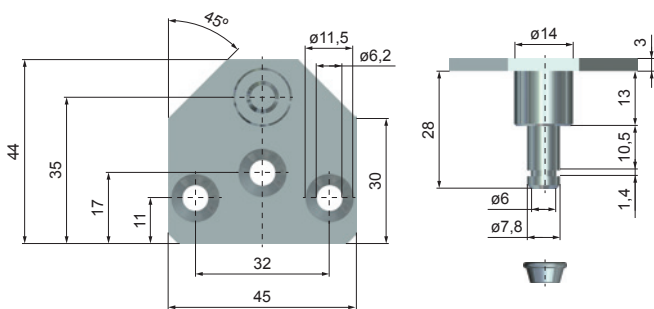

21 (für / for 1-M8, 4-M8)

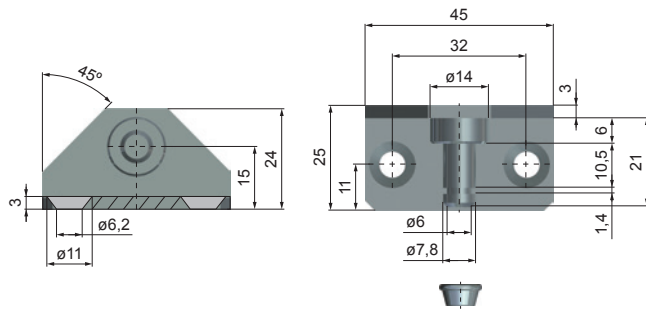

22 (für / for 1-M8, 4-M8)

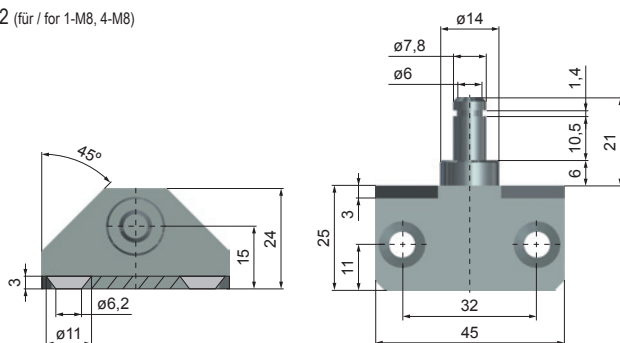

23 (für / for 5-2-M8)

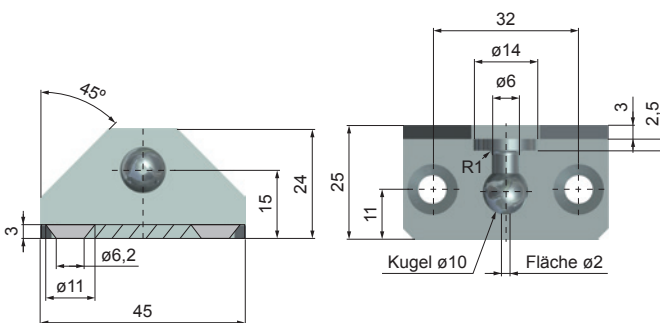

24 (für / for 5-2-M8)

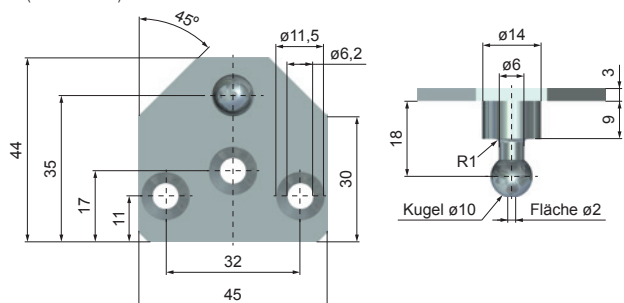

25 (für / for 1-M8, 4-M8)

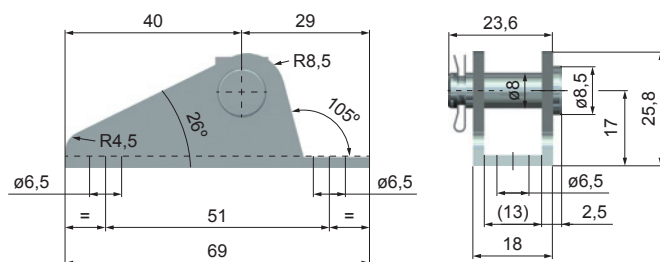

M10

1-M10 Gelenkauge • Male rod clevis
Tête de chape (male)
Attacco a cerniera maschio
Charnela macho

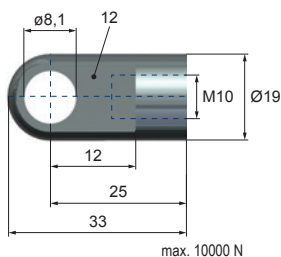

2-M10 Winkelgelenk • Angle joint
Joint à angle • Snodo angolare
Charnela articulada

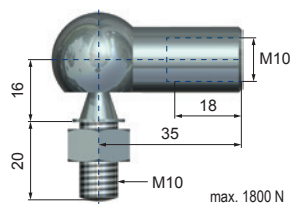

3-M10 Gabelkopf • Female rod clevis
Embout à rotule (femelle)
Forcella femmina
Charnela hembra

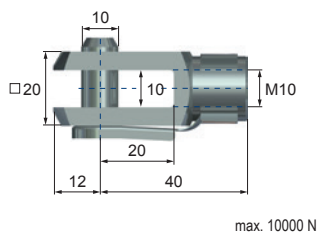

4-M10 Gelenkkopf
Spherical end bearing
Joint articulé • Forcella snodata
Charnela macho articulada

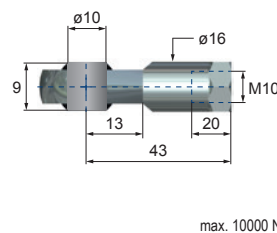

6-28-M10 Ablaßschraube • Release screw
Vis de purge • Tappo di scarico
Tornillo de vaciado

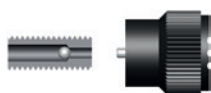

5-M10 Kugelpfanne • Ball joint housing
Cousinet sphérique
Cuscinetto sferico
Cojinete esférico

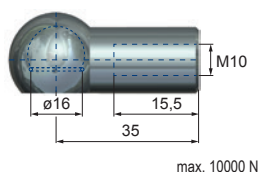

25 (für / for 1-M10)

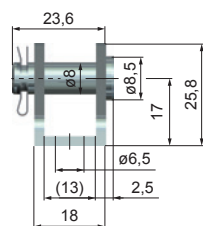
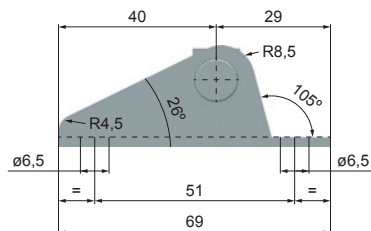

M14x1,5

1-M14 Gelenkauge • Male rod clevis
Tête de chape (male)
Attacco a cerniera maschio
Charnela macho

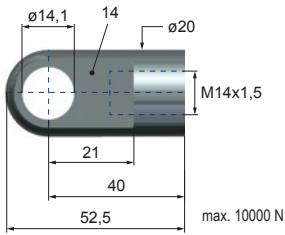

2-M14 Winkelgelenk • Angle joint
Joint à angle • Snodo angolare
Charnela articulada

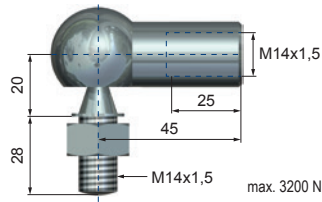

3-M14 Gabelkopf • Female rod clevis
Embout à rotule (femelle)
Forcella femmina
Charnela hembra

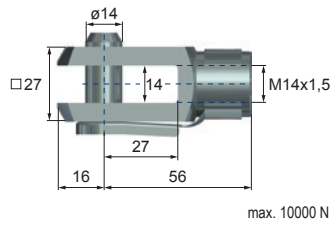

4-M14 Gelenkkopf
Spherical end bearing
Joint articulé • Forcella snodata
Charnela macho articulada

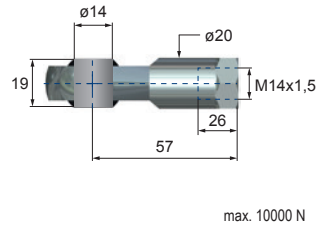

6-40-M14 Ablassschraube • Release screw
Vis de purge • Tappo di scarico
Tornillo de vaciado

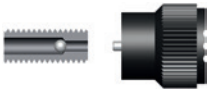

M24x2

3-M24 Gabelkopf • Female rod clevis
Embout à rotule (femelle)
Forcella femmina
Charnela hembra

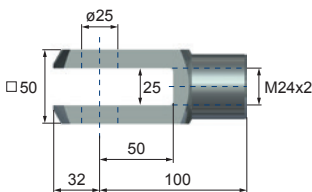

4-M24 Gelenkkopf
Spherical end bearing
Joint articulé • Forcella snodata
Charnela macho articulada

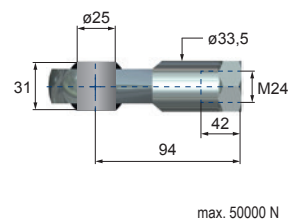

Gasfeder-Füllkoffer - Gas spring Refilling Kit



Gasfeder-Füllkoffer zum füllen und anpassen von Gasfedern vor Ort. Der Koffer enthält alle Füllglocken und Ablaßschrauben. Der Füllkoffer ist passend für 200 bar Stickstoff-Flaschen mit Gewinde W24,32x1/14". Stickstoff ist im Lieferumfang nicht enthalten.

The gas spring refilling kit allows to fill or adjust gas springs on site. The kit contains all necessary filling bells and release screws for our product range. The refilling kit is equipped for 200 bar nitrogen bottles with thread W24,32x1/14". Nitrogen is not included.

Gasfeder-Ablasskoffer - Gas Spring Release Kit



Gasfeder-Ablasskoffer zum kontrollierten Ablassen von Stickstoff bei Gasfedern. Der Koffer enthält alle notwendigen Ablaß-Schrauben und einen Manometer zum Prüfen des verbleibenden Drucks in der Gasfeder.

Gas spring release kit for controlled discharge of nitrogen in gas springs. The kit contains all necessary release screws and a pressure gauge to control the remaining pressure in the gas spring.

Gasfeder Füllstand - Gas Spring Filling Station



Gasfeder Füllstand zum Füllen von Gasfedern (außer WM-G-70). Der Füllstand wird inklusiver aller Fülladapter geliefert. Stickstoff ist im Lieferumfang nicht enthalten.

Gas spring filling station to fill gas springs (except WM-G-70). All necessary filling adapters are included. Nitrogen is not included.

Blockierbare Gasfedern · Lockable Gas Springs

Ressorts à gaz blocable · Molle a gas bloccabili

Resortes a gas bloqueables



D

▪ Hohe Korrosionsbeständigkeit

- Gehäuse: pulverbeschichtet
- Kolbenstange: keramisch beschichtet

▪ Stufenlos über den kompletten Hub arretierbar

▪ Minimale Reibungswerte für niedrigste Ausschubkräfte

- Integrierte Fettkammer und Gleitlager
- Niedrige Losbrechkraft
- Einbaulage: beliebig
- Wartungsfrei und einbaufertig
- Temperaturbereich: -30°C – +80°C, optional: -45°C – +200°C
- RoHS konform Richtlinie 2002/95/EG
- Ausschubkraft muss bei Bestellung angegeben werden

GB

▪ High corrosion resistance

- Housing: powder coated
- Piston rod: ceramic coated

▪ Freely lockable over the complete stroke

▪ Minimal friction coefficient to achieve the lowest extension forces

- Integrated grease chamber and sliding bearing
- Lower breakaway force
- Installation position: any
- Maintenance-free and ready for installation
- Temperature: -30°C – +80°C, optional: -45°C – +200°C
- RoHS compliant Directive 2002/95/EC
- Extension force must be stated on ordering.

F

▪ Résistance élevée à la corrosion

- Corps : peinture à la poudre
- Tige de piston : revêtement céramique

▪ Peuvent être arrêtés en continu sur l'ensemble de la course

▪ Valeurs de frottement minimales pour atteindre les plus faibles forces d'extension

- Chambre de lubrification et palier lisse intégrés
- Faible force de rupture
- Position de montage : au choix
- Sans maintenance et prêt à monter
- Températures: -30°C – +80°C, en option: -45°C – +200°C
- RoHS compliant Directive 2002/95/EC
- L'effort de tarage doit être précisé lors de la commande

I

▪ Elevata resistenza alla corrosione

- Corpo: rivestimento in polvere
- Stelo del pistone: rivestimento ceramico

▪ Bloccabili in modo continuo su tutta la corsa

▪ Valori d'attrito ridotti per ottenere forze d'espulsione minime

- Camera di lubrificazione e cuscinetti a strisciamento integrati
- Forza di spunto ridotta
- Posizione di montaggio: a scelta
- Senza manutenzione e pronte per il montaggio
- Temperatura: -20°C - +80°C, opzionale: -45°C - +200°C
- RoHS compliant Direttiva 2002/95/EC
- La forza di espulsione deve essere indicata quando si effettua l'ordine

E

▪ Alta resistencia a la corrosión

- Carcasa: recubrimiento en polvo
- Vástago del émbolo: revestimiento cerámico

▪ Bloqueables sin niveles en todo el recorrido

▪ Valores de fricción mínimos para conseguir las menores fuerzas de extracción

- Cámara de grasa y cojinetes deslizantes integrados
- Fuerza de arranque baja
- Posición de montaje: cualquiera
- Sin mantenimiento y listo para ser montado
- Temperaturas: -30°C – +80°C, opcional: -45°C – +200°C
- RoHS y que cumplan Directiva 2002/95/CE
- Debe indicarse la fuerza de extensión en el pedido

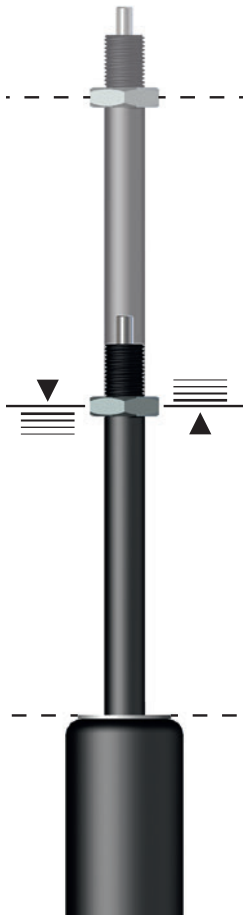

D Typ 1

- Blockierung in beide Richtungen
- Federweg trotz Blockierung möglich
- komfortable Dämpfung
- Anwendung: Sitzhöhenverstellung

GB Type 1

- Blockable in both directions
- Spring travel possible in spite of being blocked
- Comfortable shock absorption
- Application: seat height adjustment

F Type 1

- Blocage dans les deux sens
- Débattement possible malgré le blocage
- Amortissement confortable
- Application : réglage de hauteur d'assise

I Tipo 1

- Bloccaggio in entrambi i sensi
- Possibilità di deflessione nonostante il bloccaggio
- Ammortizzazione comoda
- Uso: spostamento in altezza di sedili

E Tipo 1

- Bloqueo en ambas direcciones
- A pesar del bloqueo posible alargar el resorte
- Amortiguación cómoda
- Aplicación: ajuste de la altura de los asientos

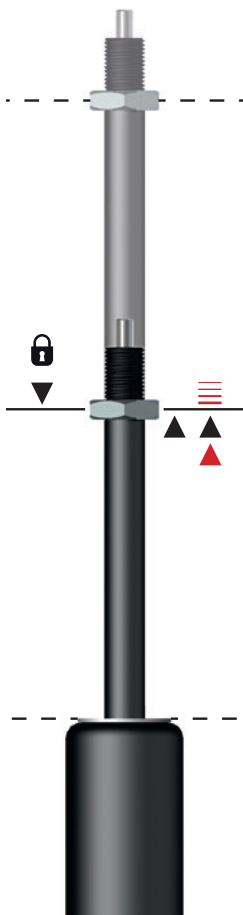

D Typ 3

- Funktionsprinzip wie bei Typ 2
- Öl- und Gasraum seitentauscht
- Anwendung: Verstellungen

GB Type 3

- Functional application as in type 2
- Oil and gas are reversed
- Application: adjusting

F Type 3

- Principe de fonctionnement similaire à celui du type 2
- Côtés des espaces huile et gaz inversés
- Application : réglages

I Tipo 3

- Stesso principio funzionale del tipo 2
- Compartimenti dell'olio e del gas invertiti lateralmente.
- Uso: spostamenti

E Tipo 3

- Principio de funcionamiento como el tipo 2
- Recinto de aceite y de gas cambiados de lado
- Aplicación: Cambios de posición

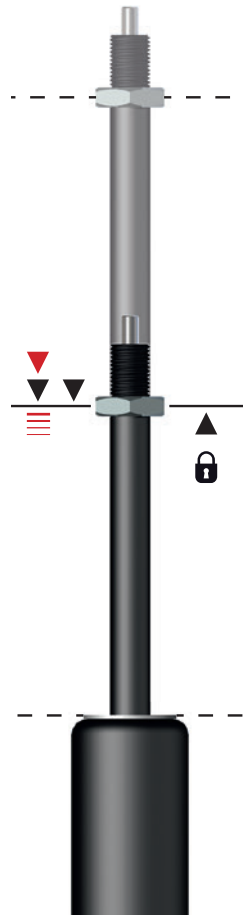

D Typ 2

- Blockierung starr bei Belastung auf Zug
- Blockierung auf Druck bleibt starr, bis die Kraft des Fülldrucks auf den Trennkolben überschritten wird.
- Anwendung: Neigungsverstellung

GB Type 2

- Fixed blocking when load is placed on the pull
- Blocking under pressure remains fixed until the force of the filling pressure on the separating piston is exceeded.
- Application: adjustable inclinations

F Type 2

- Blocage fixe en cas de sollicitation en traction
- Le blocage de la pression reste fixe jusqu'à dépassement de la force de la pression de remplissage du piston de rupture.
- Application : réglage de l'inclinaison

I Tipo 2

- Bloccaggio rigido alla sollecitazione di trazione
- Il bloccaggio a pressione rimane rigido finché non viene superata la forza della pressione di riempimento sul pistone separatore.
- Uso: regolazione dell'inclinazione

E Tipo 2

- Bloqueo rígido con carga sobre la tracción
- Bloqueo sobre presión permanece rígido, hasta que se supera la fuerza de la presión de llenado en el pistón de separación.
- Aplicación: Modificación de la inclinación

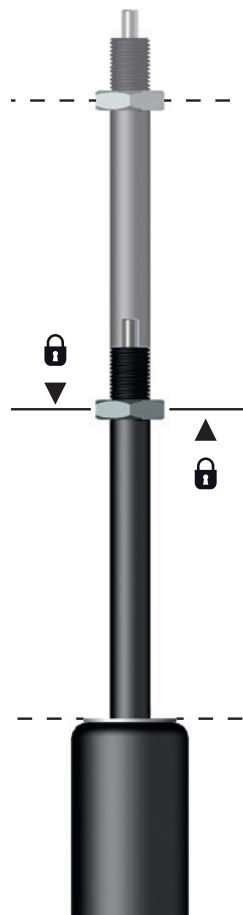

D Typ 4

- Kombination aus Typ 2 und Typ 3
- Starre Blockierung in beide Richtungen
- Anwendung: Wippmechanismen, medizinische Liegen

GB Type 4

- Combination of type 2 and type 3
- Fixed blocking in both directions
- Application: rocker mechanisms, medical couches

F Type 4

- Combinaison entre les types 2 et 3
- Blocage fixe dans les deux sens
- Application : mécanismes à bascule, lits médicaux

I Tipo 4

- Combinazione del tipo 2 e del tipo 3
- Bloccaggio rigido in entrambi i sensi
- Uso: meccanismi basculanti, lettini medici

E Tipo 4

- Combinación del tipo 2 y del tipo 3
- Bloqueo rígido en ambas direcciones
- Aplicación: mecanismos basculantes, camillas médicas

WM-GB Typ 1 / Type 1

Typ 1 · Type 1

Type 1 · Tipo 1 · Tipo 1

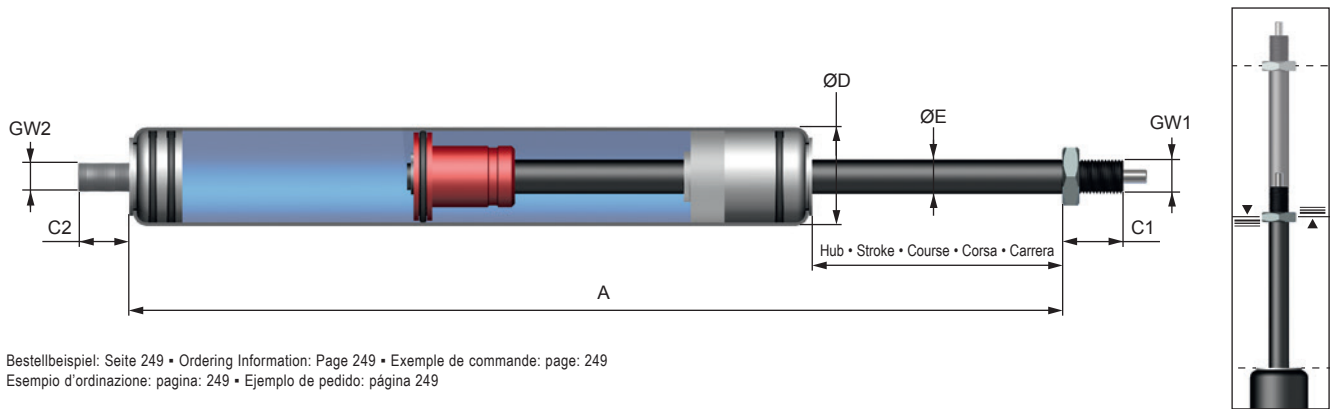

Bestellbeispiel: Seite 249 • Ordering Information: Page 249 • Exemple de commande: page: 249
Esempio d'ordinazione: pagina: 249 • Ejemplo de pedido: página 249

ABMESSUNGEN · DIMENSIONS · DIMENSIONI · DIMENSIONES

	ø D	Hub Stroke Course Corsa Carrera	Kraft · Force Force · Forza Fuerza		Progression	A	E	C1	C2	GW1	GW2
			N min.	N max.							
	mm	mm			%	mm	mm	mm	mm		
WM-GB-22-050-1	22	50	40	700	23	175	8	16	8	M 8x1	M8
WM-GB-22-100-1	22	100	40	700	23	275	8	16	8	M 8x1	M8
WM-GB-22-150-1	22	150	40	700	23	375	8	16	8	M 8x1	M8
WM-GB-22-200-1	22	200	40	700	23	475	8	16	8	M 8x1	M8
WM-GB-22-250-1	22	250	40	700	23	575	8	16	8	M 8x1	M8
WM-GB-22-300-1	22	300	40	700	23	675	8	16	8	M 8x1	M8
WM-GB-22K-050-1	22	50	50	1300	39	181	10	18	13	M 10x1	M10
WM-GB-22K-100-1	22	100	50	1300	39	281	10	18	13	M 10x1	M10
WM-GB-22K-150-1	22	150	50	1300	39	381	10	18	13	M 10x1	M10
WM-GB-22K-200-1	22	200	50	1300	39	481	10	18	13	M 10x1	M10
WM-GB-22K-250-1	22	250	50	1300	39	581	10	18	13	M 10x1	M10
WM-GB-22K-300-1	22	300	50	1300	39	681	10	18	13	M 10x1	M10
WM-GB-28-050-1	28	50	40	700	13	187	8	16	8	M 8x1	M8
WM-GB-28-100-1	28	100	40	700	13	287	8	16	8	M 8x1	M8
WM-GB-28-150-1	28	150	40	700	13	387	8	16	8	M 8x1	M8
WM-GB-28-200-1	28	200	40	700	13	487	8	16	8	M 8x1	M8
WM-GB-28-250-1	28	250	40	700	13	587	8	16	8	M 8x1	M8
WM-GB-28-300-1	28	300	40	700	13	687	8	16	8	M 8x1	M8
WM-GB-28K-050-1	28	50	50	1300	21	194	10	18	13	M 10x1	M10
WM-GB-28K-100-1	28	100	50	1300	21	294	10	18	13	M 10x1	M10
WM-GB-28K-150-1	28	150	50	1300	21	394	10	18	13	M 10x1	M10
WM-GB-28K-200-1	28	200	50	1300	21	494	10	18	13	M 10x1	M10
WM-GB-28K-250-1	28	250	50	1300	21	594	10	18	13	M 10x1	M10
WM-GB-28K-300-1	28	300	50	1300	21	694	10	18	13	M 10x1	M10
WM-GB-40-050-1	40	50	150	2600	18	201	14	20	15	M 14x1,5	M14x1,5
WM-GB-40-100-1	40	100	150	2600	18	301	14	20	15	M 14x1,5	M14x1,5
WM-GB-40-150-1	40	150	150	2600	18	401	14	20	15	M 14x1,5	M14x1,5
WM-GB-40-200-1	40	200	150	2600	18	501	14	20	15	M 14x1,5	M14x1,5
WM-GB-40-300-1	40	300	150	2600	18	701	14	20	15	M 14x1,5	M14x1,5
WM-GB-40-400-1	40	400	150	2600	18	901	14	20	15	M 14x1,5	M14x1,5
WM-GB-40-500-1	40	500	150	2600	18	1101	14	20	15	M 14x1,5	M14x1,5
WM-GB-40-600-1	40	600	150	2600	18	1301	14	20	15	M 14x1,5	M14x1,5
WM-GB-40-700-1	40	700	150	2600	18	1501	14	20	15	M 14x1,5	M14x1,5

Typ 2 · Type 2
Type 2 · Tipo 2 · Tipo 2

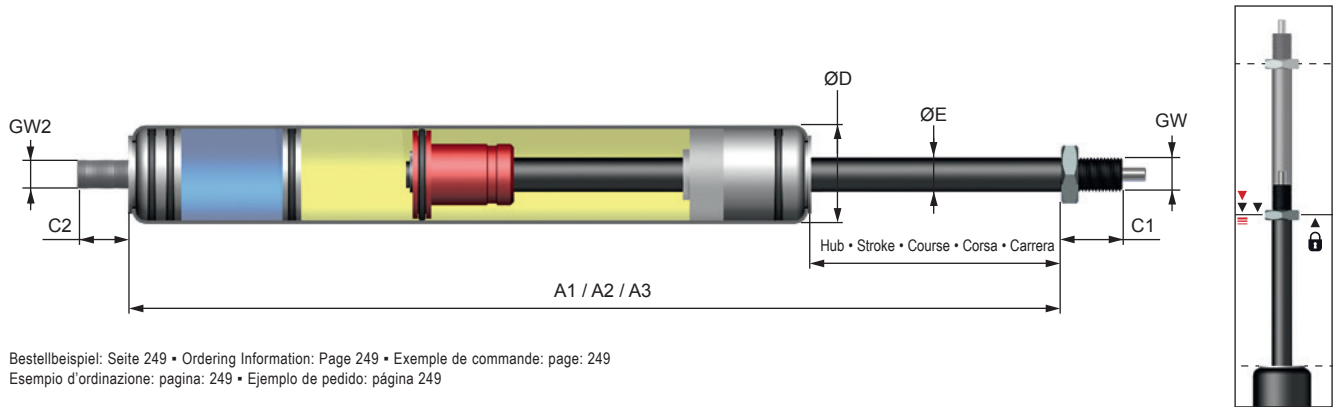

Bestellbeispiel: Seite 249 • Ordering Information: Page 249 • Exemple de commande: page: 249
Esempio d'ordinazione: pagina: 249 • Ejemplo de pedido: página 249

ABMESSUNGEN · DIMENSIONS · DIMENSIONI · DIMENSIONES

	Ø D	Hub Stroke Course Corsa Carrera	Kraft · Force Force · Forza Fuerza		A1 Progression 35%	A2 Progression 50%	A3 Progression 100%	E	C1	C2	GW1	GW2	Blockierkraft Druck* Locking force push*	Blockierkraft Zug Locking force pull
			N min.	N max.										
WM-GB-22-050-2	22	50	40	700	194	187	178	8	16	8	M 8x1	M 8	3920	-
WM-GB-22-100-2	22	100	40	700	320	305	287	8	16	8	M 8x1	M 8	3920	-
WM-GB-22-150-2	22	150	40	700	446	424	397	8	16	8	M 8x1	M 8	3920	-
WM-GB-22-200-2	22	200	40	700	572	542	506	8	16	8	M 8x1	M 8	3920	-
WM-GB-22-250-2	22	250	40	700	698	661	616	8	16	8	M 8x1	M 8	3920	-
WM-GB-22-300-2	22	300	40	700	824	779	725	8	16	8	M 8x1	M 8	3920	-
WM-GB-22K-050-2	22	50	40	1300	214	202	188	10	18	13	M 10x1	M 10	3920	7000
WM-GB-22K-100-2	22	100	40	1300	354	331	303	10	18	13	M 10x1	M 10	3920	7000
WM-GB-22K-150-2	22	150	40	1300	495	460	418	10	18	13	M 10x1	M 10	3920	7000
WM-GB-22K-200-2	22	200	40	1300	635	589	533	10	18	13	M 10x1	M 10	3920	7000
WM-GB-22K-250-2	22	250	40	1300	776	718	648	10	18	13	M 10x1	M 10	3920	7000
WM-GB-22K-300-2	22	300	40	1300	916	847	763	10	18	13	M 10x1	M 10	3920	7000
WM-GB-28-050-2	28	50	50	700	189	184	179	8	16	8	M 8x1	M 8	7000	-
WM-GB-28-100-2	28	100	50	700	305	296	285	8	16	8	M 8x1	M 8	7000	-
WM-GB-28-150-2	28	150	50	700	422	408	392	8	16	8	M 8x1	M 8	7000	-
WM-GB-28-200-2	28	200	50	700	538	520	498	8	16	8	M 8x1	M 8	7000	-
WM-GB-28-250-2	28	250	50	700	655	632	605	8	16	8	M 8x1	M 8	7000	-
WM-GB-28-300-2	28	300	50	700	771	744	711	8	16	8	M 8x1	M 8	7000	-
WM-GB-28K-050-2	28	50	50	1300	203	195	187	10	18	13	M 10x1	M 10	10000	10000
WM-GB-28K-100-2	28	100	50	1300	329	313	296	10	18	13	M 10x1	M 10	10000	10000
WM-GB-28K-150-2	28	150	50	1300	455	431	406	10	18	13	M 10x1	M 10	10000	10000
WM-GB-28K-200-2	28	200	50	1300	581	549	515	10	18	13	M 10x1	M 10	10000	10000
WM-GB-28K-250-2	28	250	50	1300	707	667	625	10	18	13	M 10x1	M 10	10000	10000
WM-GB-28K-300-2	28	300	50	1300	833	744	734	10	18	13	M 10x1	M 10	10000	10000
WM-GB-40-100-2	40	100	150	2600	342	330	314	14	20	15	M 14x1,5	M 14x1,5	10000	10000
WM-GB-40-150-2	40	150	150	2600	464	446	422	14	20	15	M 14x1,5	M 14x1,5	10000	10000
WM-GB-40-200-2	40	200	150	2600	585	561	529	14	20	15	M 14x1,5	M 14x1,5	10000	10000
WM-GB-40-300-2	40	300	150	2600	828	792	744	14	20	15	M 14x1,5	M 14x1,5	10000	10000
WM-GB-40-400-2	40	400	150	2600	1071	1023	959	14	20	15	M 14x1,5	M 14x1,5	10000	10000
WM-GB-40-500-2	40	500	150	2600	1314	1254	1174	14	20	15	M 14x1,5	M 14x1,5	10000	10000
WM-GB-40-600-2	40	600	150	2600	1557	1485	1389	14	20	15	M 14x1,5	M 14x1,5	10000	10000
WM-GB-40-700-2	40	700	150	2600	1800	1716	1604	14	20	15	M 14x1,5	M 14x1,5	10000	10000

*Angabe sind ca. Werte - abhängig von der Ausschubkraft "F1"
*Data are approximate - depending on the extension force "F1"

Zubehör Seite 240 • Accessories Page 240 • Accessoires Page 240
Accessori Pagina 240 • Accesorios Página 240

Typ 3 · Type 3

Type 3 · Tipo 3 · Tipo 3

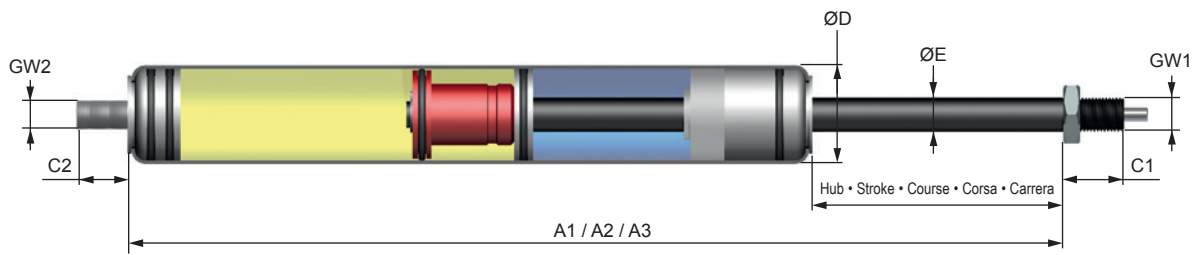

! ohne Ventil / without valve

Bestellbeispiel: Seite 249 • Ordering Information: Page 249 • Exemple de commande: page: 249
Esempio d'ordinazione: pagina: 249 • Ejemplo de pedido: página 249

ABMESSUNGEN - DIMENSIONS - DIMENSIONI - DIMENSIONES

	Ø D	Hub Stroke Course Carrera	Kraft • Force Force • Forza Fuerza		A1 - Progression 35%	A2 - Progression 50%	A3 - Progression 100%	E	C1	C2	GW1	GW2	Blockierkraft Druck* Locking force push*	Blockierkraft Zug* Locking force pull*
			N min.	N max.									N max	N max
WM-GB-22-050-3	22	50	40	700	216	206	196	8	16	8	M 8x1	M8	7000	-
WM-GB-22-100-3	22	100	40	700	357	338	317	8	16	8	M 8x1	M8	7000	-
WM-GB-22-150-3	22	150	40	700	499	470	439	8	16	8	M 8x1	M8	7000	-
WM-GB-22-200-3	22	200	40	700	640	602	560	8	16	8	M 8x1	M8	7000	-
WM-GB-22K-050-3	22	50	50	1300	254	239	219	10	18	13	M 10x1	M10	7000	3380
WM-GB-22K-100-3	22	100	50	1300	427	396	357	10	18	13	M 10x1	M10	7000	3380
WM-GB-22K-150-3	22	150	50	1300	600	554	495	10	18	13	M 10x1	M10	7000	3380
WM-GB-22K-200-3	22	200	50	1300	773	711	633	10	18	13	M 10x1	M10	7000	3380
WM-GB-22K-250-3	22	250	50	1300	946	869	771	10	18	13	M 10x1	M10	7000	3380
WM-GB-22K-300-3	22	300	50	1300	1119	1026	909	10	18	13	M 10x1	M10	7000	3380
WM-GB-28-050-3	28	50	50	700	202	196	191	8	16	8	M 8x1	M8	7000	7000
WM-GB-28-100-3	28	100	50	700	326	313	303	8	16	8	M 8x1	M8	7000	7000
WM-GB-28-150-3	28	150	50	700	450	431	416	8	16	8	M 8x1	M8	7000	7000
WM-GB-28-200-3	28	200	50	700	574	548	528	8	16	8	M 8x1	M8	7000	7000
WM-GB-28-250-3	28	250	50	700	698	666	641	8	16	8	M 8x1	M8	7000	7000
WM-GB-28-300-3	28	300	50	700	822	783	753	8	16	8	M 8x1	M8	7000	7000
WM-GB-28K-050-3	28	50	50	1300	226	217	206	10	18	13	M 10x1	M10	10000	7000
WM-GB-28K-100-3	28	100	50	1300	366	348	327	10	18	13	M 10x1	M10	10000	7000
WM-GB-28K-150-3	28	150	50	1300	507	480	448	10	18	13	M 10x1	M10	10000	7000
WM-GB-28K-200-3	28	200	50	1300	647	611	569	10	18	13	M 10x1	M10	10000	7000
WM-GB-28K-250-3	28	250	50	1300	788	743	690	10	18	13	M 10x1	M10	10000	7000
WM-GB-28K-300-3	28	300	50	1300	928	874	811	10	18	13	M 10x1	M10	10000	7000
WM-GB-40-050-3	40	50	150	2600	227	220	211	14	20	15	M 14x1,5	M 14x1,5	10000	10000
WM-GB-40-100-3	40	100	150	2600	361	346	328	14	20	15	M 14x1,5	M 14x1,5	10000	10000
WM-GB-40-150-3	40	150	150	2600	495	473	446	14	20	15	M 14x1,5	M 14x1,5	10000	10000
WM-GB-40-200-3	40	200	150	2600	629	599	563	14	20	15	M 14x1,5	M 14x1,5	10000	10000
WM-GB-40-300-3	40	300	150	2600	897	852	798	14	20	15	M 14x1,5	M 14x1,5	10000	10000
WM-GB-40-400-3	40	400	150	2600	1165	1105	1033	14	20	15	M 14x1,5	M 14x1,5	10000	10000
WM-GB-40-500-3	40	500	150	2600	1433	1356	1268	14	20	15	M 14x1,5	M 14x1,5	10000	10000
WM-GB-40-600-3	40	600	150	2600	1701	1611	1503	14	20	15	M 14x1,5	M 14x1,5	10000	10000

*Angabe sind ca. Werte - abhängig von der Ausschubkraft "F1"
*Data are approximate - depending on the extension force "F1"

Zubehör Seite 240 • Accessories Page 240 • Accessoires Page 240
Accessori Pagina 240 • Accesorios Página 240

Typ 4 · Type 4
Type 4 · Tipo 4 · Tipo 4

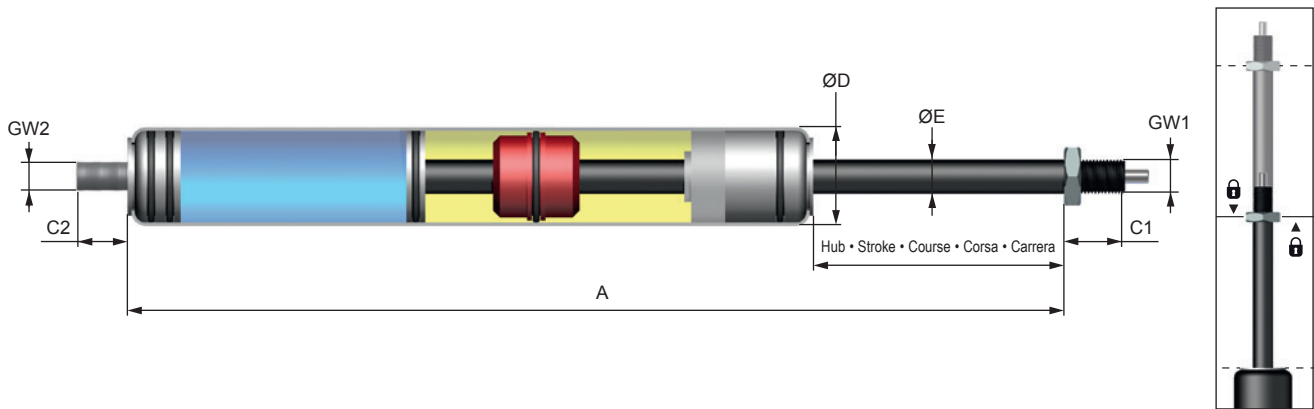

Bestellbeispiel: Seite 249 • Ordering Information: Page 249 • Exemple de commande: page: 249
Esempio d'ordinazione: pagina: 249 • Ejemplo de pedido: página 249

ABMESSUNGEN - DIMENSIONS - DIMENSIONI - DIMENSIONES

	ø D	Hub • Stroke • Course Corsa • Carrera	Kraft • Force • Force Forza • Fuerza		A	E	C1	C2	GW1	GW2	Blockierkraft Druck* Locking force push*	Blockierkraft Zug* Locking force pull*
			N min.	N max.							N max	N max
	mm	mm			mm	mm	mm	mm				
WM-GB-22K-050-4	22	50	50	1300	233	10	18	13	M 10x1	M10	7000	7000
WM-GB-22K-100-4	22	100	50	1300	383	10	18	13	M 10x1	M10	7000	7000
WM-GB-22K-150-4	22	150	50	1300	533	10	18	13	M 10x1	M10	7000	7000
WM-GB-22K-200-4	22	200	50	1300	683	10	18	13	M 10x1	M10	7000	7000
WM-GB-22K-250-4	22	250	50	1300	833	10	18	13	M 10x1	M10	7000	7000
WM-GB-28K-50-4	28	50	50	1300	237	10	18	13	M 10x1	M10	10000	10000
WM-GB-28K-100-4	28	100	50	1300	387	10	18	13	M 10x1	M10	10000	10000
WM-GB-28K-150-4	28	150	50	1300	537	10	18	13	M 10x1	M10	10000	10000
WM-GB-28K-200-4	28	200	50	1300	687	10	18	13	M 10x1	M10	10000	10000
WM-GB-28K-250-4	28	250	50	1300	837	10	18	13	M 10x1	M10	10000	10000
WM-GB-40-050-4	40	50	150	2600	239	14	20	15	M 14x1,5	M 14x1,5	12000	12000
WM-GB-40-100-4	40	100	150	2600	389	14	20	15	M 14x1,5	M 14x1,5	12000	12000
WM-GB-40-150-4	40	150	150	2600	539	14	20	15	M 14x1,5	M 14x1,5	12000	12000
WM-GB-40-200-4	40	200	150	2600	689	14	20	15	M 14x1,5	M 14x1,5	12000	12000
WM-GB-40-250-4	40	250	150	2600	839	14	20	15	M 14x1,5	M 14x1,5	12000	12000

Zubehör Seite 240 • Accessories Page 240 • Accessoires Page 240 • Accessori Pagina 240 • Accesorios Página 240

- ! Bauartbedingt kann es zu einem Spiel von bis zu 2mm kommen. Darf dies nicht vorkommen, muss die Gasfeder mit **-EL** bestellt werden.
Due to the size, there may be a slip of 2mm. If this is not allowed, you have to order the gas spring with **-EL**.
- En raison de la taille, il peut y avoir un glissement de 2mm. Si cela n'est pas autorisé, vous devez commander le ressort à gaz avec **-EL**.
A causa delle dimensioni, potrebbe esserci uno slittamento di 2 mm. Se questo non è consentito, è necessario ordinare la molla a gas con **-EL**.
Debido a su tamaño, puede haber un deslizamiento de 2 mm. Si esto no está permitido, debe pedir el pistón a gas con **-EL**.

Bestellbeispiel • Ordering Information • Exemple de commande • Esempio d'ordinazione • Ejemplo de pedido

WM-GB-22-100-2-K0G1-XXXX-XXXX

WM-GB	Blockierbare Gasfedern • Lockable Gas Springs • Ressort à gaz blocable • Molle a gas bloccabili • Resortes a Gas Bloqueables
22	22 mm Durchmesser • 22 mm diameter • 22 mm diamètre • 22 mm diametro • 22 mm de diámetro
100	Hub • Stroke • Course • Corsa • Carrera
-2	Typ • Type • Type • Tipo • Tipo
-EL nur Typ 4 only Type 4	Typ 4 ohne Spiel • Type 4 without slip • Type 4 sans glissement • Tipo 4 senza slittamento • Tipo 4 sin deslizamiento
K0G1	Kolbenstange - nur Gewinde • Piston rod - only thread • Tige de piston - seulement des filetages • Stelo del pistone - filettatura solo • Vástago del émbolo - sólo rosca Gehäuse - Gelenkauge • Housing - Male rod clevis • Corps - Tête de chape • Corpo - Attacco a cerniera maschio • Carcasa - Charnela macho
Code	Code wird von Weforma bei Bestellung vergeben • Code is assigned by Weforma • Code est attribué par Weforma Codice assegnato dal Weforma • Código es asignado por Weforma

Auslösungen · Release Systems

Déclenchements · Disinnesti · Accionamientos

Weforma

8.3. Hydraulik Auslösung Klassik
 Bitte wählen Sie die gewünschte Ausführung

Gasfeder	Typ 1	Zubehör	
Typ:	200 mm	Auslösung:	Hydraulik-Auslösung
Hub:	100 N	Variante:	Klassik, 5.2
Ausschubkraft:	39 %	L1:	
Progression:	481 mm	L2:	
Einbaulänge EL2:	10/22 mm	L3:	
Durchmesser:	G0	Geberabgang:	Gerade
Zubehör Gehäuse:	493 mm	Zubehör:	
Einbaulänge EL1:			

BOWDENZUG-AUSLÖSUNG · BOWDEN WIRE RELEASE SYSTEM

DÉCLENCHEMENT PAR CÂBLE BOWDEN · DISINNESTO A CAVO · DESCONEXIÓN DE TRACCIÓN BOWDEN

A Auslöserkopf (Standard, Zink-Druckguss)
 Release head (Standard, Zinc die cast)

Auslöserkopf (Waagrecht, Zink-Druckguss)
 Release head (Horizontal, Zinc die cast)

AK7

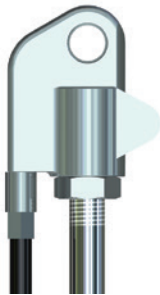

AK8

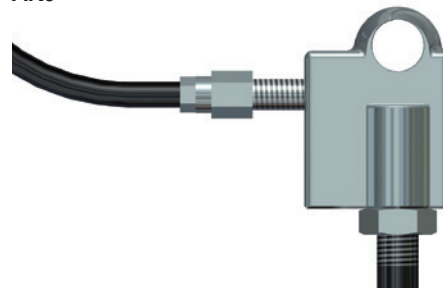

B **BO-1000**

Bowdenzug
 Bowden wire



C

T1
 Taster Kunststoff mit Feder
 Push button plastic
 with spring



T2
 Taster Kunststoff
 ohne Feder
 Push button plastic
 without spring

T3
 Taster Alu mit Feder
 Push button alu
 with spring



T4
 Taster Alu ohne Feder
 Push button alu
 without spring

T5
 Taster mit langer Buchse Alu,
 ohne Feder

Push button with long
 bushing, aluminium,
 without spring



HEBELAUSLÖSUNG • RELEASE SYSTEM WITH LEVER
DÉCLENCHEMENT PAR LEVIER • DISINNESTO A LEVA • DESCONEJÓN DE PALANCA

AK5-D

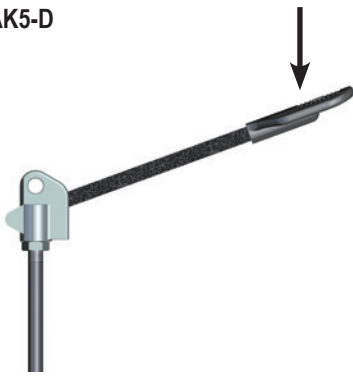

Auslösehebel
 (Auslöserichtung hin zur Feder)
 Auslösekopf, Hebel, Flachgriff

Release System with Lever
 (release dir. towards gas spring)
 Release head, Release lever
 Flat grip for release lever

AK5-U

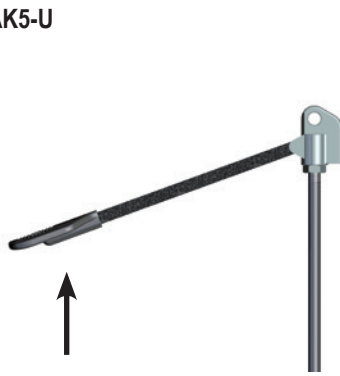

Auslösehebel
 (Auslöserichtung weg von der Feder)
 Auslösekopf, Hebel, Flachgriff

Release System with Lever
 (release dir. away from gas spring)
 Release head, Release lever
 Flat grip for release lever

AK6

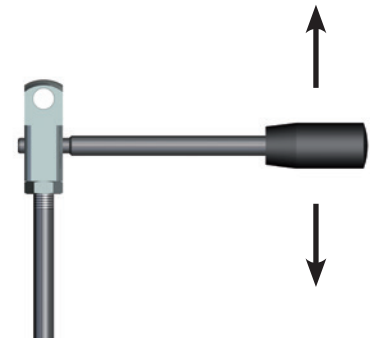

Hebelauslösung variabel
 Auslösekopf, Hebel
 Konusgriff für Auslösehebel

Variable release lever
 Release head, Release lever
 Cone grip for release lever

HYDRAULISCHE AUSLÖSUNG • HYDRAULIC RELEASE SYSTEM
DÉCLENCHEMENT HYDRAULIQUE • DESCONEJÓN HIDRÁULICA • DISINNESTO IDRAULICO

Kurzauslösung
 mit / ohne Taster

Short release system
 with / without push button

AK10



TH1

Kunststoff-Buchse +
 Kunststoff -Taster

Plastic bushing + Plastic
 push button



TH3

Alu-Buchse +
 Kunststoff-Taster

Aluminium bushing +
 Plastic push button



TH5

Alu-Buchse +
 Alu-Taster

Aluminium bushing +
 Aluminium push button



Архангельск (8182)63-90-72
Астана (7172)727-132
Астрахань (8512)99-46-04
Барнаул (3852)73-04-60
Белгород (4722)40-23-64
Брянск (4832)59-03-52
Владивосток (423)249-28-31
Волгоград (844)278-03-48
Вологда (8172)26-41-59
Воронеж (473)204-51-73
Екатеринбург (343)384-55-89
Иваново (4932)77-34-06

Ижевск (3412)26-03-58
Иркутск (395)279-98-46
Казань (843)206-01-48
Калининград (4012)72-03-81
Калуга (4842)92-23-67
Кемерово (3842)65-04-62
Киров (8332)68-02-04
Краснодар (861)203-40-90
Красноярск (391)204-63-61
Курск (4712)77-13-04
Липецк (4742)52-20-81
Киргизия (996)312-96-26-47

Магнитогорск (3519)55-03-13
Москва (495)268-04-70
Иркутск (395)279-98-46
Мурманск (8152)59-64-93
Набережные Челны (8552)20-53-41
Новокузнецк (3843)20-46-81
Новосибирск (383)227-86-73
Омск (3812)21-46-40
Орел (4862)44-53-42
Оренбург (3532)37-68-04
Пенза (8412)22-31-16
Россия (495)268-04-70

Пермь (342)205-81-47
Ростов-на-Дону (863)308-18-15
Рязань (4912)46-61-64
Самара (846)206-03-16
Санкт-Петербург (812)309-46-40
Саратов (845)249-38-78
Севастополь (8692)22-31-93
Симферополь (3652)67-13-56
Смоленск (4812)29-41-54
Сочи (862)225-72-31
Ставрополь (8652)20-65-13
Казахстан (772)734-952-31

Сургут (3462)77-98-35
Тверь (4822)63-31-35
Томск (3822)98-41-53
Тула (4872)74-02-29
Тюмень (3452)66-21-18
Ульяновск (8422)24-23-59
Уфа (347)229-48-12
Хабаровск (4212)92-98-04
Челябинск (351)202-03-61
Череповец (8202)49-02-64
Ярославль (4852)69-52-93